

**E-LEARNING MATERIAL**  
**ON**  
**ENGINEERING PHYSICS**  
**OF**  
**DIPLOMA COURSES**

# CONTENTS

<b>UNIT</b>	<b>TOPIC</b>	<b>PAGE</b>
1	UNITS AND DIMENSIONS	01
2	SCALARS AND VECTORS	10
3	KINEMATICS	21
4	WORK & FRICTION	32
5	GRAVITATION	40
6	OSCILLATIONS & WAVES	51
7	HEAT & THERMODYNAMICS	60
8	OPTICS	80
9	ELECTROSTATICS & MAGNETOSTATICS	93
10	CURRENT ELECTRICITY	115
11	ELECTROMAGNETISM & ELECTROMAGNETIC INDUCTION	122
12	MODERN PHYSICS	129
13	REFERENCE BOOKS	136

# **SYLLABUS**

## **UNIT 1 - UNITS AND DIMENSIONS**

- 1.1 Physical quantities - (Definition).
- 1.2 Definition of fundamental and derived units, systems of units (FPS, CGS, MKS and SI units).
- 1.3 Definition of dimension and Dimensional formulae of physical quantities.
- 1.4 Dimensional equations and Principle of homogeneity.
- 1.5 Checking the dimensional correctness of Physical relations.

## **UNIT 2 - SCALARS AND VECTORS**

- 2.1 Scalar and Vector quantities (definition and concept), Representation of a Vector - examples, types of vectors.
- 2.2 Triangle and Parallelogram law of vector Addition (Statement only). Simple Numerical.
- 2.3 Resolution of Vectors - Simple Numericals on Horizontal and Vertical components.
- 2.4 Vector multiplication (scalar product and vector product of vectors).

## **UNIT 3 - KINEMATICS**

- 3.1 Concept of Rest and Motion.
- 3.2 Displacement, Speed, Velocity, Acceleration & FORCE (Definition, formula, dimension & SI units).
- 3.3 Equations of Motion under Gravity (upward and downward motion) - no derivation.
- 3.4 Circular motion: Angular displacement, Angular velocity and Angular acceleration (definition, formula & SI units).
- 3.5 Relation between -(i) Linear & Angular velocity, (ii) Linear & Angular acceleration).
- 3.6 Define Projectile, Examples of Projectile.
- 3.7 Expression for Equation of Trajectory, Time of Flight, Maximum Height and Horizontal Range for a projectile fired at an angle, Condition for maximum Horizontal Range.

#### **UNIT 4 – WORK AND FRICTION**

- 4.1 Work - Definition, Formula & SI units.
- 4.2 Friction - Definition & Concept.
- 4.3 Types of friction (static, dynamic), Limiting Friction (Definition with Concept).
- 4.4 Laws of Limiting Friction (Only statement, No Experimental Verification).
- 4.5 Coefficient of Friction - Definition & Formula, Simple Numericals.
- 4.6 Methods to reduce friction.

#### **UNIT 5 - GRAVITATION**

- 5.1 Newton's Laws of Gravitation - Statement and Explanation.
- 5.2 Universal Gravitational Constant (G)- Definition, Unit and Dimension.
- 5.3 Acceleration due to gravity (g)- Definition and Concept.
  
- 5.4 Definition of mass and weight.
- 5.5 Relation between g and G.
- 5.6 Variation of g with altitude and depth (No derivation - Only Explanation).
- 5.7 Kepler's Laws of Planetary Motion (Statement only).

#### **UNIT 6 - OSCILLATIONS AND WAVES**

- 6.1 Simple Harmonic Motion (SHM) - Definition & Examples.
- 6.2 Expression (Formula/Equation) for displacement, velocity, acceleration of a body/ particle in SHM.
- 6.3. Wave motion - Definition & Concept.
- 6.4 Transverse and Longitudinal wave motion - Definition, Examples & Comparison.
- 6.5 Definition of different wave parameters (Amplitude, Wavelength, Frequency, Time Period).
- 6.6 Derivation of Relation between Velocity, Frequency and Wavelength of a wave
- 6.7 Ultrasonics - Definition, Properties & Applications.

## **UNIT 7 - HEAT AND THERMODYNAMICS**

- 7.1 Heat and Temperature - Definition & Difference
- 7.2 Units of Heat (FPS, CGS, MKS & SI).
- 7.3 Specific Heat (concept, definition, unit, dimension and simple numerical)
- 7.4 Change of state (concept), Latent Heat (concept, definition, unit, dimension and simple numerical)
- 7.5 Thermal Expansion - Definition & Concept
- 7.6 Expansion of Solids (Concept)
- 7.7 Coefficient of linear, superficial and cubical expansions of Solids - Definition & Units.
- 7.8** Relation between  $\alpha$ ,  $\beta$  &  $\gamma$
- 7.9 Work and Heat - Concept & Relation.
- 7.10 Joule's Mechanical Equivalent of Heat (Definition, Unit)
- 7.11 First Law of Thermodynamics (Statement and concept only)

## **UNIT 8 – OPTICS**

- 8.1 Reflection & Refraction - Definition.
- 8.2 Laws of reflection and refraction (Statement only)
- 8.3 Refractive index - Definition, Formula & Simple numerical.
- 8.4 Critical Angle and Total internal reflection - Concept, Definition & Explanation
- 8.5 Refraction through Prism (Ray Diagram & Formula only - NO derivation)..
- 8.6 Fiber Optics - Definition, Properties & Applications.

## **UNIT 9 – ELECTROSTATICS & MAGNETOSTATICS**

- 9.1 Electrostatics - Definition & Concept.
- 9.2 Statement & Explanation of Coulombs laws, Definition of Unit charge.
- 9.3 Absolute & Relative Permittivity ( $\epsilon$ ) - Definition, Relation & Unit.
- 9.4 Electric potential and Electric Potential difference (Definition, Formula & SI Units).
- 9.5 Electric field, Electric field intensity (E) - Definition, Formula & Unit.
- 9.6 Capacitance - Definition, Formula & Unit.
- 9.7 Series and Parallel combination of Capacitors (No derivation, Formula for effective/Combined/total capacitance & Simple numericals).
- 9.8 Magnet, Properties of a magnet.

- 9.9 Coulomb's Laws in Magnetism - Statement & Explanation, Unit Pole (Definition).
- 9.10 Magnetic field, Magnetic Field intensity (H) - (Definition, Formula & SI Unit).
- 9.11 Magnetic lines of force ( Definition and Properties)
- 9.12 Magnetic Flux ( $\Phi$ ) & Magnetic Flux Density ( $B$ ) - Definition, Formula & Unit.

### **UNIT 10 – CURRENT ELECTRICITY**

- 10.1 Electric Current - Definition, Formula & SI Units.
- 10.2 Ohm's law and its applications.
- 10.3 Series and Parallel combination of resistors (No derivation, Formula for effective/ Combined/ total resistance & Simple numericals).
- 10.4 Kirchhoff's laws (Statement & Explanation with diagram).
- 10.5 Application of Kirchhoff's laws to Wheatstone bridge - Balanced condition of Wheatstone's Bridge - Condition of Balance (Equation).

### **UNIT 11 – ELECTROMAGNETISM & ELECTROMAGNETIC INDUCTION**

- 11.1 Electromagnetism - Definition & Concept.
- 11.2 Force acting on a current carrying conductor placed in a uniform magnetic field, Fleming's Left Hand Rule
- 11.3 Faraday's Laws of Electromagnetic Induction (Statement only)
- 11.4 Lenz's Law (Statement)
- 11.5 Fleming's Right Hand Rule
- 11.6 Comparison between Fleming's Right Hand Rule and Fleming's Left Hand Rule.

### **UNIT 12 - MODERN PHYSICS**

- 12.1 LASER & laser beam (Concept and Definition)
- 12.2 Principle of LASER (Population Inversion & Optical Pumping)
- 12.3 Properties & Applications of LASER
- 12.4 Wireless Transmission - Ground Waves, Sky Waves, Space Waves  
( Concept & Definition)

# UNIT 1

## UNITS AND DIMENSIONS

Physics explains the law of nature in a special way. This explanation includes a quantitative description, comparison, and measurement of certain physical quantities. To measure or compare a physical quantity we need to fix some standard unit and dimension of the quantity. In this chapter we will discuss the basic concept of Units and Dimensions and its application to various physical problems.

### 1.1 Physical quantities -

Law of physics can be expressed through certain measurable quantities which are called as Physical quantities.

Physical quantities are divided into two categories.

- (1) Fundamental Quantities
- (2) Derived Quantities

#### 1.1.1 Fundamental Quantities

Fundamental quantities are those that do not depend on any other physical quantities for their measurements.

There are different systems of units which will be discussed in the coming sections. In each system of units, there are a set of defined fundamental quantities and fundamental units.

Mass (M), length (L) and time(T) are some of the examples of fundamental quantities.

#### 1.1.2 Derived Quantities

The physical quantities which are expressed in terms of other physical quantities are called as Derived Quantities.

Example- Velocity=Length/Time

Acceleration=Velocity/Time=Length/(Time)<sup>2</sup>

Force = Mass X Acceleration = Mass X Length/(Time)<sup>2</sup>

## 1.2 Unit

Unit is a standard which is used to measure a physical quantity.

### 1.2.1 Fundamental Units

Fundamental units are those units which are independent and not related to each other. The units of fundamental quantities are called as Fundamental Units.

Example - The unit of length is meter. So, meter is an example of fundamental unit. Similarly, second is the fundamental unit of time and kg is the fundamental unit of mass.

### 1.2.2 Derived Units

The units of the physical quantities which can be expressed in terms of fundamental units are called as Derived Units.

Example- Area = length X breadth = metre X metre = (metre)<sup>2</sup>

Velocity = displacement/time=metre/second

### 1.2.3 Systems of Unit

A complete set of units, both fundamental and derived for all physical quantities is called a system of units. The following systems of units are commonly in use.

### 1.2.3(A) C. G. S. System

This system is based on Centimetre, Gram, Second as the fundamental units of length, mass and time respectively. This system is also known as French system. In this system, unit of force is taken as dyne, unit of energy as erg, unit of power as erg/sec and unit of heat energy as calorie.

### 1.2.3(B) F. P. S. System

This system is based on Foot, Pound, Second as the fundamental units of length, mass and time respectively. This system is also known as British system. In this system unit of force is taken as „poundal“, unit of energy as „foot poundal“, unit of power as „foot poundal/sec“ and unit of heat energy as British thermal unit (BTU).

### 1.2.3(C) M. K. S. System

This system is based on Metre, Kilogram, Second as the fundamental units of length, mass and time respectively. This system is also known as Metric system. In this system unit of force is taken as Newton, unit of energy as Joule, unit of power as Joule/sec and unit of heat energy as Joule.

### 1.2.3(D) SI Units (Système International d'Unités or International System of Units)

In C.G.S and M.K.S. system, there are three fundamental quantities e.g. mass, length, and time and accordingly three fundamental units., which are insufficient to measure some physical quantities. Therefore in 1971, the International Bureau of Weights and Measures decided a system of units which is known as International System of Units and abbreviated as SI System. It is based on the seven fundamental units and two supplementary units.

#### 1.2.3(D)(i) Fundamental Units

The fundamental units used to measure in SI System, are given in the following table.

Fundamental Physical Quantity	Name of the Unit	Symbol of the Unit
(1) Mass	Kilogram	Kg
(2) Length	Metre	m
(3) Time	Second	s
(4) Thermodynamic Temperature	Kelvin	K
(5) Electric Current	Ampere	A
(6) Luminosity	Candela	cd
(7) Amount of substance	Mole	mol

#### 1.2.3(D)(ii) Supplementary units

The supplementary units of SI System, are given in the following table.

Supplementary Physical Quantity	Name of the Unit	Symbol of the Unit
(1) Angle	Radian	Rad
(2) Solid angle	Steradian	Sr

### 1.3.1 DIMENSIONS

Dimensions are the power to which the fundamental units/ quantities be raised in order to represent a physical quantity.

Example:- (1) Area = length X breadth = L X L =  $[L^2] = [M^0 L^2 T^0]$

Here 0, 2, and 0 are the dimensions of Area with respect to mass, length and time.

$$(2) \text{ Velocity} = \frac{\text{Displacement}}{\text{Time}} = \frac{[L]}{[T]} = [L^1T^{-1}] = [M^0L^1T^{-1}]$$

Here 0, 1, and -1 are the dimensions of velocity with respect to mass, length and time.

### 1.3.2 DIMENSIONAL FORMULA

Dimensional formula is a formula which tells us, how and which fundamental units must be used to express a physical quantity.

**Dimensional formula of a derived physical quantity is the “expression showing powers to which different fundamental units are raised”.**

Example:- (1) Volume(V) = length X breadth X height = L X L X L =  $[L^3] = [M^0L^3T^0]$

$$\Rightarrow V = [M^0L^3T^0]$$

This is the dimensional formula of volume.

And 0, 3, and 0 are the dimensions of volume with respect to mass, length and time.

$$(2) \text{ Acceleration}(a) = \frac{\text{Velocity}}{\text{Time}} = \frac{[L^1T^{-1}]}{[T]} = [L^1T^{-2}] = [M^0L^1T^{-2}]$$

$$\Rightarrow a = [M^0L^1T^{-2}]$$

This is the dimensional formula of acceleration. Here 0, 1, and -2 are the dimensions of acceleration with respect to mass, length and time.

$$(3) \text{ Momentum} = \text{mass} \times \text{velocity} = [M^1][L^1T^{-1}] = [M^1L^1T^{-1}]$$

$$(4) \text{ Force} = \text{mass} \times \text{acceleration} = [M^1][L^1T^{-2}] = [M^1L^1T^{-2}]$$

$$(5) \text{ Moment of a force} = \text{force} \times \text{distance} = [M^1L^1T^{-2}][L^1] = [M^1L^2T^{-2}]$$

$$(6) \text{ Work} = \text{force} \times \text{distance} = [M^1L^1T^{-2}][L^1] = [M^1L^2T^{-2}]$$

$$(7) \text{ Kinetic Energy} (E_k) = \frac{1}{2}mv^2$$

$$= \frac{1}{2}[M^1][L^1T^{-1}]^2 \quad [1/2 \text{ has been ignored because}$$

$$= [M^1][L^2T^{-2}] \quad \text{it is dimensionless}]$$

$$= [M^1L^2T^{-2}]$$

$$(8) \text{ Potential Energy} (E_p) = mgh$$

$$= [M^1][L^1T^{-2}][L^1]$$

$$= [M^1L^2T^{-2}]$$

$$(9) \text{ Specific heat capacity} (s)$$

$Q = ms\theta$ , where Q = heat energy, m = mass, s = specific heat capacity,  $\theta$  = thermodynamic temperature.

$$\Rightarrow s = \frac{Q}{m\theta} = \frac{[M^1L^2T^{-2}]}{[M^1][K^1]} = [M^0L^2T^{-2}K^{-1}]$$

Here 0, 2, -2 and -1 are the dimensions of specific heat capacity with respect to mass, length, time, and temperature.

$$(10) \text{ Specific Latent Heat}(l)$$

$$Q = ml$$

$$\Rightarrow l = \frac{Q}{m} = \frac{[M^1L^2T^{-2}]}{[M^1]} = [M^0L^2T^{-2}]$$

Here, 0,2, -2 are the dimensions of specific latent heat with respect to mass, length, and time.

(11) Charge (q)

$$i = \frac{q}{t}$$

$$\Rightarrow q = it = [A^1][T^1] = [A^1T^1]$$

Here 1 and 1 are the dimensions of charge with respect to current and time.

(12) Thermal Conductivity (K)

$$Q = K \frac{A(\theta_1 - \theta_2)t}{l}$$

$$\Rightarrow K = \frac{Ql}{A(\theta_1 - \theta_2)t}$$

$$= \frac{[M^1L^1T^{-2}][L^1]}{[L^2][K^1][T^1]} = [M^1L^{-1}T^{-3}K^{-1}]$$

[Where Q= heat energy

l=length of the rod

A=cross sectional area

( $\theta_1 - \theta_2$ )=temperature difference

Here, 1,1,-3,-1 are the dimensions of thermal conductivity with respect to mass, length, time and temperature.

SI. No	Physical Quantity	Formula	Dimensional Formula	S.I Unit
1	Area (A)	Length x Breadth	$[M^0L^2T^0]$	$m^2$
2	Volume (V)	Length x Breadth x Height	$[M^0L^3T^0]$	$m^3$
3	Density (d)	Mass / Volume	$[M^1L^{-3}T^0]$	$kgm^{-3}$
4	Speed (s)	Distance / Time	$[M^0L^1T^{-1}]$	$ms^{-1}$
5	Velocity (v)	Displacement / Time	$[M^0L^1T^{-1}]$	$ms^{-1}$
6	Acceleration (a)	Change in velocity / Time	$[M^0L^1T^{-2}]$	$ms^{-2}$
7	Acceleration due to gravity (g)	Change in velocity / Time	$[M^0L^1T^{-2}]$	$ms^{-2}$
8	Linear momentum (p)	Mass x Velocity	$[M^1L^1T^{-1}]$	$kgms^{-1}$
9	Force (F)	Mass x Acceleration	$[M^1L^1T^{-2}]$	N (Newton) ( $kgms^{-2}$ )
10	Work (W)	Force. Displacement	$[M^1L^2T^{-2}]$	J (Joule) ( $kgm^2s^{-2}$ )
11	Energy (E)	Work	$[M^1L^2T^{-2}]$	J
12	Impulse (I)	Force x Time	$[M^1L^1T^{-1}]$	Ns
13	Pressure (P)	Force / Area	$[M^1L^{-1}T^{-2}]$	$Nm^{-2}$
14	Power (P)	Work / Time	$[M^1L^2T^{-3}]$	W (Watt)
15	Universal constant of gravitation (G)	$\frac{\text{Force x (Distance)}^2}{(\text{Mass})^2}$	$[M^{-1}L^3T^{-2}]$	$Nm^2kg^{-2}$
16	Thrust (F)	Force	$[M^1L^1T^{-2}]$	N
17	Tension (T)	Force	$[M^1L^1T^{-2}]$	N
18	Stress	Force / Area	$[M^1L^{-1}T^{-2}]$	$Nm^{-2}$
19	Strain	Change in dimension / Original dimension	No dimensions $[M^0L^0T^0]$	No unit
20	Angle ( $\theta$ ) Angular Displacement	Arc length / Radius	No dimensions $[M^0L^0T^0]$	Rad
21	Angular velocity( $\omega$ )	Angle / Time	$[M^0L^0T^{-1}]$	$rad s^{-1}$
22	Angular acceleration( $\alpha$ )	Angular velocity / Time	$[M^0L^0T^{-2}]$	$rad s^{-2}$
23	Wavelength ( $\lambda$ )	Length of a wavelet	$[M^0L^1T^0]$	M
24	Frequency(f)	Number of vibrations/second or 1/time period	$[M^0L^0T^{-1}]$	Hz or $s^{-1}$
25	Angular momentum (J)	Moment of inertia x Angular velocity	$[M^1L^2T^{-1}]$	$kgm^2s^{-1}$

26	Temperature	Temperature	$[M^0L^0T^0K^1]$	K
27	Heat (Q)	Energy	$[M^1L^2T^{-2}]$	J
28	Latent heat (L)	Heat / Mass	$[M^0L^2T^{-2}]$	Jkg <sup>-1</sup>
29	Specific heat (S)	$\frac{\text{Heat}}{\text{mass} \times \text{temperature}}$	$[M^0L^2T^{-2}K^{-1}]$	Jkg <sup>-1</sup> K <sup>-1</sup>
30	Thermal expansion coefficient or thermal expansivity	$\frac{\text{Change in dimension}}{\text{original dimension} \times \text{temperature}}$	$[M^0L^0T^0K^{-1}]$	K <sup>-1</sup>
31	Thermal conductivity	$\frac{\text{Heat Energy} \times \text{thickness}}{\text{Area} \times \text{temperature}}$	$[M^1L^{-1}T^{-2}K^{-1}]$	Wm <sup>-1</sup> K <sup>-1</sup>
32	Charge (q)	Current x time	$[M^0L^0T^1A^1]$	C (Coulomb)
33	Electric potential (V), voltage, electromotive force	Work / Charge	$[M^1L^2T^{-2}A^{-1}]$	V (Volt)
34	Resistance (R)	Potential difference / Current	$[M^1L^2T^{-2}A^{-2}]$	Ω ohm
35	Capacitance	Charge / potential difference	$[M^{-1}L^{-2}T^4A^2]$	F (Farad)
36	Electrical resistivity or (electrical conductivity) <sup>-1</sup>	$\frac{\text{Resistance} \times \text{Area}}{\text{length}}$	$[M^1L^3T^{-2}A^{-2}]$	Ωm
37	Electric field (E)	Force / Charge	$[M_1L_3T^{-2}A^{-1}]$	NC <sup>-1</sup>
38	Electric flux	Electric field X area	$[M L T A ]$	Nm <sup>2</sup> C <sup>-1</sup>
39	Electric field strength or electric intensity	Potential difference / distance	$[M^1L^1T^{-2}A^{-1}]$	Volt/meter or NC <sup>-1</sup>
40	Magnetic field (B), magnetic flux density, magnetic induction	$\frac{\text{Force}}{\text{current} \times \text{length}}$	$[M^1L^0T^{-2}A^{-1}]$	T (Tesla)
41	Magnetic flux (Φ)	Magnetic field X area	$[M^1L^2T^{-2}A^{-1}]$	Wb (Weber)
42	Kinetic energy	$\frac{1}{2} \times \text{Mass} \times (\text{Velocity})^2$	$[M^1L^2T^{-2}]$	J
43	Potential energy	Mass X acceleration due to gravity X height	$[M^1L^2T^{-2}]$	J
44	Efficiency	$\frac{\text{Output work or energy}}{\text{Input work or energy}}$	No dimensions $[M^0L^0T^0]$	No unit
45	Permittivity of free space	$\frac{\text{Charge} \times \text{Charge}}{\text{Electric force} \times \text{Distance} \times \text{Distance}}$	$[M^{-1}L^{-3}T^4A^2]$	F m <sup>-1</sup>
46	Permeability of free space	$\frac{\text{Force} \times \text{Distance}}{\text{current} \times \text{current} \times \text{length}}$	$[M L T A ]$	NA <sup>-2</sup>
47	Refractive index	$\frac{\text{Speed of light in vacuum}}{\text{Speed of light in medium}}$	No dimensions $[M^0L^0T^0]$	No unit

#### 1.4.1 Dimensional Equation

When the dimensional formula of a physical quantity is expressed in the form of an equation by writing the physical quantity on the left hand side and the dimensional formula on the right hand side, then the resultant equation is called Dimensional equation.

Example:- Work(W) = Force X displacement

$$= [M^1L^1T^{-2}][L^1]$$

$$= [M^1L^2T^{-2}]$$

$$\Rightarrow W = [M^1L^2T^{-2}] \text{----- (i)}$$

This equation is known as dimensional equation.

### 1.4.2 Use of dimensional analysis

Dimensional analysis has following three uses.

- (i) To convert the value of a physical quantity from one system to another.
- (ii) To derive a relation between various physical quantities.
- (iii) To check the correctness of a given relation.

### 1.4.3 Principle of Homogeneity

It states that the dimensional formula of every term on both sides of a correct relation must be same.

OR,

The dimensions of each of the terms of a dimensional equation on both sides should be the same.

### 1.4.4 To convert the value of a physical quantity from one system to another

Using dimensional analysis, we can find the numerical value of a physical quantity in any system if the numerical value is known in another system.

Example:- convert a work of 5 Joule in to erg.

Solution:-

(M.K.S.) System-1 (Value known)	(WORK) [M <sup>a</sup> L <sup>b</sup> T <sup>c</sup> ] 2]	(C.G.S.) System-2 (Value unknown)
M <sub>1</sub> =1 kg	a=1	M <sub>2</sub> =1 g
L <sub>1</sub> =1 m	b=2	L <sub>2</sub> =1 cm
T <sub>1</sub> =1 s	c=-2	T <sub>2</sub> =1 s
n <sub>1</sub> =5		n <sub>2</sub> =?

Physical quantity as represented in system 1 =  $n_1[M_1^a L_1^b T_1^c]$

Physical quantity as represented in system 2 =  $n_2[M_2^a L_2^b T_2^c]$

Since the quantity are same in both the system, then

$$n_1[M_1^a L_1^b T_1^c] = n_2[M_2^a L_2^b T_2^c]$$

$$\Rightarrow n_2 = n_1 \left[ \frac{M_1}{M_2} \right]^a \left[ \frac{L_1}{L_2} \right]^b \left[ \frac{T_1}{T_2} \right]^c$$

Substituting the value as given in the problem we get,

$$n_2 = 5 \left[ \frac{1\text{kg}}{1\text{g}} \right]^1 \left[ \frac{1\text{m}}{1\text{cm}} \right]^2 \left[ \frac{1\text{s}}{1\text{s}} \right]^{-2} = 5 \left[ \frac{1000\text{g}}{1\text{g}} \right]^1 \left[ \frac{100\text{cm}}{1\text{cm}} \right]^2 \left[ \frac{1\text{s}}{1\text{s}} \right]^{-2} = 5 \times 10^7 \text{erg}$$

∴ 1 Joule = 10<sup>7</sup> erg

### 1.4.5 To derive a relation between various physical quantities by the method of dimensional analysis:

Relation of one physical quantity with others can be derived when the factors on which this quantity depends are known to us.

Example:- Obtain an expression for centripetal force required to move a body of mass „m“, with velocity „v“ in a circle of radius „r“.

Solution:- Let the centripetal force depend upon m, v, r as follows:

$$F \propto m^a, F \propto v^b, F \propto r^c$$

Here a, b, c are dimensionless constants.

$$F \propto m^a v^b r^c$$

$$\Rightarrow F = k m^a v^b r^c \text{-----(i)}$$

Here k is a dimensionless constant.

Writing the dimensional formulae of physical quantities in above equation, we get

$$[M^1 L^1 T^{-2}] = [M^1][L^1 T^{-1}]^b [L^1]^c$$

$$\Rightarrow [M^1 L^1 T^{-2}] = [M^a L^{b+c} T^{-b}]$$

Now comparing the dimensions on both sides, we get

$$a = 1 \text{-----(ii)}$$

$$b+c = 1 \text{-----(iii)}$$

$$-b = -2 \text{-----(iv)}$$

From equation (iv), b=2,

Now substituting the value of b in equation (iii), we get c=-1.

Putting the values of a=1, b=2, c=-1 in equation (i), we get

$$F = k \frac{mv^2}{r}$$

This is the required expression.

### 1.5 Checking the dimensional correctness of Physical relations.

To check the correctness of a relation, we find the dimensional formula of every term on both sides of the relation. If the dimensions are same then the relation is said to be dimensionally correct.

Example(1):- To check the correctness of given relation.

$$s = ut + \frac{1}{2} at^2$$

Solution:- Given relation is  $s = ut + \frac{1}{2} at^2$

$$\text{Dimensional formula of } s = \text{Displacement} = [L^1] = [M^0 L^1 T^0] \text{----- (i)}$$

$$\text{Dimensional formula of } ut = [M^0 L^1 T^{-1}][T^1] = [M^0 L^1 T^0] \text{-----(ii)}$$

$$\text{Dimensional formula of } \frac{1}{2} at^2 = [M^0 L^1 T^{-2}][T^2] = [M^0 L^1 T^0] \text{----- (iii)}$$

From the above equations we get dimensional formula of every term are same.

Therefore, according to Principle of Homogeneity the given relation is dimensionally correct.

Example(2):- To check the correctness of given relation.

$$v = u + at$$

Solution:- Given relation is  $v = u + at$

$$\text{Dimensional formula of } v = \text{final velocity} = [M^0 L^1 T^{-1}] \text{-----(i)}$$

$$\text{Dimensional formula of } u = \text{initial velocity} = [M^0 L^1 T^{-1}] \text{----- (ii)}$$

$$\text{Dimensional formula of } at = [M^0 L^1 T^{-2}][T^1] = [M^0 L^1 T^{-1}] \text{-----(iii)}$$

From the above equations we get dimensional formula of every term are same.

Therefore, according to Principle of Homogeneity the given relation is dimensionally correct.

Example(3):- To check the correctness of given relation.

$$v^2 - u^2 = 4as$$

Solution:- Given relation is  $v^2 - u^2 = 4as$

Dimensional formula of  $v^2 = [M^0L^1T^{-1}]^2 = [M^0L^2T^{-2}]$ ----- (i)

Dimensional formula of  $u^2 = [M^0L^1T^{-1}]^2 = [M^0L^2T^{-2}]$ ----- (ii)

Dimensional formula of  $2as = [M^0L^1T^{-2}][L] = [M^0L^2T^{-2}]$ ----- (iii)

From the above equations we get dimensional formula of every term are same.

Therefore, according to Principle of Homogeneity the given relation is dimensionally correct.

Question:- To check the correctness of following relation.

(1)  $t = 2\pi\sqrt{\frac{g}{l}}$  where  $g$ =acceleration due to gravity and  $l$ =length of thread,  $t$  = time period.

(2)  $F = \frac{mv}{r}$  where  $v$  = velocity,  $r$  = radius,  $m$  = Mass

Solution:-

(1) Given relation is  $t = 2\pi\sqrt{\frac{g}{l}}$

Dimensional formula of L.H.S =  $t = [M^0L^0T^1]$ ----- (i)

Dimensional formula of  $g = [M^0L^1T^{-2}]$ ----- (ii)

Dimensional formula of R.H.S =  $2\pi\sqrt{\frac{g}{l}} = \sqrt{\frac{[M^0L^1T^{-2}]}{[L^1]}} = \sqrt{[M^0L^0T^{-2}]}$   
 $= [M^0L^0T^{-1}]^{1/2}$   
 $= [M^0L^0T^{-1}]$ ----- (iii)

Here Dimension of L.H.S  $\neq$  Dimension of R.H.S

From the above equations we get that the dimensional formula of the terms on both the sides are not same. Therefore according to Principle of Homogeneity the given relation is dimensionally incorrect.

(2) Given relation is  $F = \frac{mv}{r}$

Dimensional formula of  $F = [M^1L^1T^{-2}]$ ----- (i)

Dimensional formula of  $v = [M^0L^1T^{-1}]$ ----- (ii)

Dimensional formula of L.H.S =  $F = [M^1L^1T^{-2}]$

Dimensional formula of R.H.S =  $\frac{mv^2}{r} = \frac{M [M^0L^1T^{-1}]^2}{L}$   
 $= [M^1L^1T^{-2}]$ ----- (iii)

Here, Dimensional formula of L.H.S = Dimensional formula of R.H.S

From the above equations we get that the dimensional formula of the terms on both the sides are same. Therefore according to Principle of Homogeneity the given relation is dimensionally correct.

# EXERCISE

## VERY SHORT ANSWER QUESTIONS(2 Marks each)

1. Name two quantities which are dimensionless in nature.  
[Ans. Angle and strain]
2. Name two quantities which have dimensional formula [  $M^1L^{-1}T^{-2}$  ]  
[Ans. Pressure and Stress]
3. Obtain the dimension of (i) pressure (ii) Kinetic Energy  
[Ans.(i) [  $M^1L^{-1}T^{-2}$  ] and (ii) [  $M^1L^2T^{-2}$  ]]
4. What is meant by a unit?  
[Ans. Unit is a standard which is used to measure a physical quantity.]
5. How are Megameter and nanometer related with each other?  
[ Ans. 1 Megameter =  $10^{15}$  nanometer ]
6. Write the dimensional formula of force and work.  
[Ans. Force = [  $M^1L^1T^{-2}$  ] and Work = [  $M^1L^2T^{-2}$  ]]
7. Write the SI unit and dimensional formula of electric Potential.  
[Ans. Volt and [  $M^1L^2T^{-3}A^{-1}$  ]]
8. Write down the dimensional formula for Gravitational constant.  
[Ans. [  $M^{-1}L^3T^{-2}$  ]]

## SHORT ANSWER QUESTIONS (5 Marks each)

1. Write the fundamental units in S.I. system.
2. Prove that the dimensions of kinetic energy and potential energy are same.
3. Check the correctness of the following (i)  $v^2 - u^2 = 2as$ , (ii)  $s = ut + \frac{1}{2}at^2$
4. Obtain the dimensional formula of Thermal Conductivity.
5. Obtain the dimensional formula of Specific heat capacity.

## LONG ANSWER QUESTIONS (10 Marks each)

1. States the principle of Homogeneity and check the correctness of following relation. (i)  $t = 2\pi \sqrt{\frac{l}{g}}$  and (ii)  $v = \sqrt{\frac{E}{\rho}}$ , where symbols have their usual meanings
2. Prove that (i) 1 Newton =  $10^5$  dyne and (ii) 1Joule =  $10^7$  erg by the method of dimensional analysis.
3. Time period of a simple pendulum (T) depends upon length of the pendulum and acceleration due to gravity; find the expression for time period by the method of dimensional analysis.

## UNIT 2

### SCALARS AND VECTORS

We have come across with different types of physical quantities, in one dimensional motion, only two directions are possible. So directional aspect of the quantities like position, displacement, velocity and acceleration can be taken care by using positive and negative signs. But in the case of motion in two dimensions (plane) or three dimensions (space), an object can have large number of directions. In order to deal with such situation effectively, we need to introduce the concept of scalar and vector quantities.

In this chapter we shall discuss the definition of scalar and vector quantities, its applications to solve different physical problems and how they can be multiplied.

#### 2.1 Scalar Quantities and Vector Quantities

The physical quantities are classified into two categories

(i) Scalar Quantities and (ii) Vector quantities.

##### 2.1.1 Scalar quantities

Scalar quantities are those quantities which require only the magnitude for their complete specification.

Example:- mass, length, volume, time, distance, speed, density, energy, temperature, electric charge, electric potential etc.

##### 2.1.2 Vector quantities

Vector quantities are those quantities which require magnitude as well as direction for their complete specification and satisfies the law of vector addition.

Example:- Displacement, velocity, acceleration, force, momentum, electric field, magnetic field, magnetic moment etc.

##### 2.1.3 Vector

A directed line segment is called as vector. When it is written over the head of a physical quantity, then it represents a vector quantity.

##### 2.1.4 Representation of a vector

A vector „ $A$ “ (Fig. 2.1) can be represented by an arrow „ $OP$ “ of finite length directed from initial point  $O$  to the terminal point  $P$ . The length of arrow represents the magnitude of vector and the arrow head denotes the direction of the vector.

A vector is written with an arrow head over its symbol like „ $\vec{A}$ “. The magnitude of given vector is represented by modulus of vector ( $|A|$ ) or simply „ $A$ “.

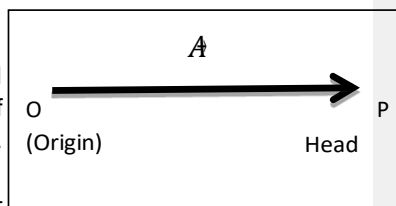

##### 2.1.4 Types of vector

There are different types of vectors.

- (i) **Null vector**:-It is a vector having zero magnitude and an arbitrary direction. It is represented by a point or dot ( $\bullet$ ). When a null vector is added or subtracted from a given vector, the resultant vector is same as the given vector. Dot product of a null vector with any other vector is always zero. Cross product of a null vector with any other vector is also a null vector.

- (ii) **Unit vector** :- Any vector whose magnitude is one unit is called as a unit vector. A unit vector only specifies the direction of given vector. A unit vector in the direction of vector  $\vec{A}$  is written as  $\hat{A}$  and is read as „A cap“.

$$\vec{A} = \hat{A} A \quad \text{or} \quad \hat{A} = \frac{\vec{A}}{A}$$

In three dimensional coordinate system, unit vectors along positive X, Y and Z-axes are usually represented by  $\hat{i}$ ,  $\hat{j}$  and  $\hat{k}$  respectively. These unit vectors are mutually perpendicular to each other (Fig.2.2)

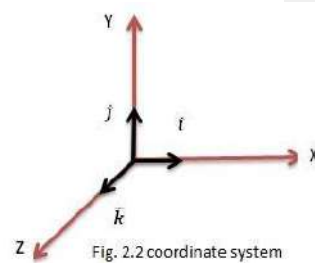

- (iii) **Collinear vectors**

Vector having a common line of action are called as collinear vectors. There are of two types of collinear vectors.

- (a) **Parallel vectors ( $\theta=0^\circ$ )**:-Two vectors acting along same direction irrespective of their magnitude are called as parallel vectors. Vectors  $\vec{A}$  and  $\vec{B}$  shown in fig. 2.3 are parallel vectors. Angle between them is zero.

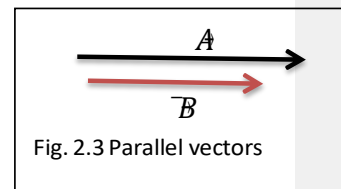

- (b) **Anti-parallel vectors ( $\theta=180^\circ$ )**:-Two vectors acting along opposite direction irrespective of their magnitude are called as anti-parallel vectors. Vectors  $\vec{A}$  and  $\vec{B}$  shown in fig 2.4 are anti-parallel vectors. Angle between them is  $180^\circ$ .

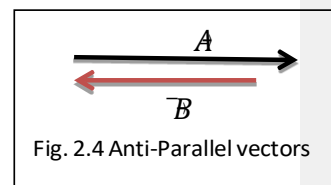

- (iv) **Perpendicular vectors ( $\theta=90^\circ$ )**

Two vectors are said to be perpendicular when they are normal to each other (irrespective of their magnitude). Vectors  $\vec{A}$  and  $\vec{B}$  shown in fig 2.5 are perpendicular vectors. Angle between them is  $90^\circ$ .

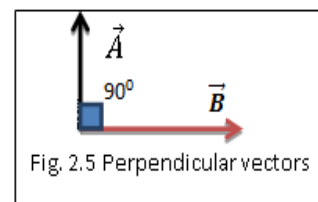

- (v) **Equal vectors**

Two vectors are said to be equal if they possess same magnitude and direction. Vectors  $\vec{A}$  and  $\vec{B}$  shown in fig 2.6 are equal vectors. All equal vectors are parallel vectors.

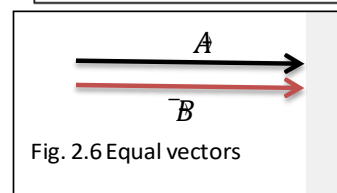

- (vi) **Negative vector**

A vector is said to be negative vector of another one if they possess same magnitude and opposite direction. Vectors  $\vec{A}$  and  $\vec{B}$  shown in fig 2.7 are negative vector to each other. All negative vectors are anti-parallel vectors.

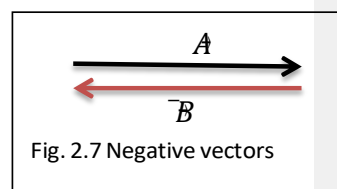

**(vii) Co-initial vectors**

A number of vectors are said to be co-initial when they have common initial point. Vectors  $\vec{A}$ ,  $\vec{B}$ ,  $\vec{C}$ ,  $\vec{D}$  and  $\vec{E}$  shown in fig 2.8 are co-initial vectors, started from a common point P.

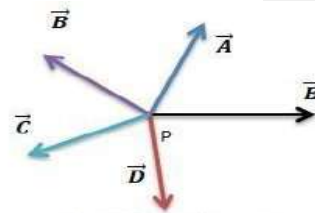

Fig. 2.8 Co-initial vectors

**(viii) Co-planar vectors**

A number of vectors are said to be co-planar when they are lying in the same plane. Vectors  $\vec{A}$ ,  $\vec{B}$ ,  $\vec{C}$ ,  $\vec{D}$  and  $\vec{E}$  shown in fig 2.9 are co-planar vectors, present in the same plane.

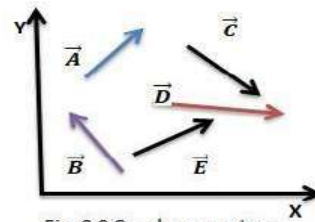

Fig. 2.9 Co-planar vectors

**(ix) Position Vector**

Vectors that indicate the position of a point in a coordinate system is called as position vector. Let point P(x,y,z) present in three coordinate system then,  $\vec{R}$  is the position vector of point P from the origin O(0,0,0) as shown in the fig 2.10.

Position vector can be written as

$$\vec{R} = x\hat{i} + y\hat{j} + z\hat{k}$$

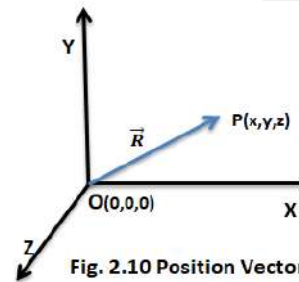

Fig. 2.10 Position Vector

**2.2 Addition of vectors**

Vectors cannot be added according to the simple algebra, because vectors have magnitude along with direction. So vector can be added as follows.

**2.2.1 Triangle law of vector addition**

It is a law for the addition of two vectors. It can be stated as follows:

“If two vectors acting simultaneously on a body are represented in magnitude and direction by two adjacent sides of a triangle taken in same order, then the resultant vector is represented in magnitude and direction by third side of that triangle taken in opposite order”.

Let two vectors  $\vec{A}$  and  $\vec{B}$  acting at a point be represented by two sides  $\vec{OP}$  and  $\vec{PQ}$  of triangle OPQ, taken in same order (Fig. 2.11). According to triangle law of vector addition, the third side  $\vec{OQ}$  represents the resultant vector  $\vec{R}$  taken in opposite order.

$$\vec{R} = \vec{A} + \vec{B}$$

It can be mathematically proved that:

$$R = \sqrt{A^2 + B^2 + 2AB \cos \theta}$$

And  $Q = \tan^{-1} \left( \frac{\sin \theta}{A + B \cos \theta} \right)$

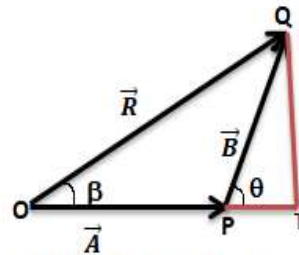

Fig. 2.11 Vector addition by Triangle law

### 2.2.2 Parallelogram's law of vector addition

Two vectors can also be added by using parallelogram's law of vector addition. It can be stated as follows:

“If two vectors acting simultaneously on a body are represented in magnitude and direction by two adjacent sides of a parallelogram drawn from a point, then the resultant vector is represented in magnitude and direction by the diagonal of the parallelogram passing through that point”.

Let two vectors  $\vec{A}$  and  $\vec{B}$  acting at a point, be represented by two adjacent sides  $\vec{OP}$  and  $\vec{OQ}$  of Parallelogram OPTQ, drawn from a point (Fig. 2.12). According to parallelogram law of vector addition, the diagonal  $\vec{OT}$  of parallelogram represent the resultant vector  $\vec{R}$  passing through that point.

$$\vec{R} = \vec{A} + \vec{B}$$

It can be mathematically proved that:

$$R = \sqrt{A^2 + B^2 + 2AB \cos \theta}$$

And  $Q = \tan^{-1} \left( \frac{B \sin \theta}{A + B \cos \theta} \right)$

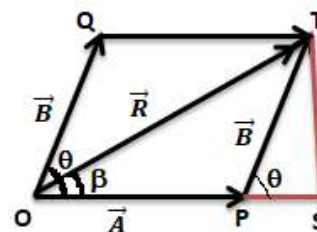

Fig. 2.12 Parallelogram law

### 2.3 Resolution of Vectors in a plane-

The process of splitting a vector into various parts or components is called "RESOLUTION OF VECTOR"

Resolution of a vector is the process of obtaining the component vectors which when combined according to the law of vector addition, produce the given vector.

Let  $\vec{O}(\vec{R})$  be the position vector of point P(x,y) in XY-plane(Fig. 2.13). From P draw the perpendiculars PQ and PB on X-axis and Y-axis respectively. It makes an angle  $\theta$  with X-axis.

Let  $\hat{i}$  and  $\hat{j}$  are the unit vectors along x-axis and Y-axis respectively.

Consider  $\vec{R}$  resolves into two components horizontal component  $\vec{R}_x$  along X-axis and vertical component  $\vec{R}_y$  along Y-axis.

According to triangle law of vector addition in triangle OPQ we can write

$$\vec{R} = \vec{R}_x + \vec{R}_y$$

$$\Rightarrow \vec{R} = \hat{i} R_x + \hat{j} R_y \text{ ..... (i)}$$

In the  $\Delta OPQ$ ,  $\cos \theta = \frac{OQ}{OP}$

$$\Rightarrow \cos \theta = \frac{R_x}{R} \text{ ..... (ii)}$$

Again in  $\Delta OPQ$ ,  $\sin \theta = \frac{QP}{OP} = \frac{R_y}{R}$

$$\Rightarrow \sin \theta = \frac{R_y}{R} \text{ ..... (iii)}$$

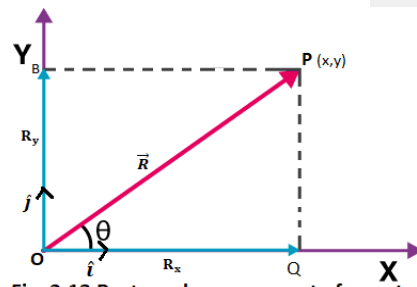

Fig. 2.13 Rectangular component of a vector

Now putting the values of equation (ii) and (iii) in equation (i), we get:

$$\vec{R} = \hat{i} R \cos \theta + \hat{j} R \sin \theta$$

## 2.4 Vector multiplication

There are two ways in which two vectors can be multiplied together.

- (i) Scalar Product or Dot product
- (ii) Vector Product or Cross product

### 2.4.1 Scalar product or Dot product

Dot product between two vectors is defined as the product of their magnitude and the cosine of the smaller angle between them.

It is written by putting a dot ( $\cdot$ ) between two vectors. The result of this product does not possess any direction. Hence it is also called as Scalar product.

Consider two vectors  $\vec{A}$  and  $\vec{B}$  drawn from a point and inclined to each other at angle  $\theta$  as shown in the Fig.2.14.

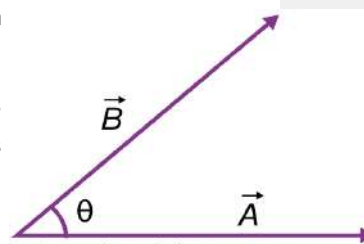

Fig. 2.14 dot product between two vectors

Dot product of  $\vec{A}$  and  $\vec{B}$  is given by

$$\vec{A} \cdot \vec{B} = AB \cos \theta$$

For ,  $\theta=90^\circ$

$$\vec{A} \cdot \vec{B} = AB \cos \theta = AB \cos 90^\circ = AB \times 0 = 0 \quad [\cos 90^\circ = 0]$$

Thus the dot product of two non-zero vectors, which are perpendicular to each other is always zero.

Since  $\hat{i}, \hat{j}$  and  $\hat{k}$  are mutually perpendicular to each other (Fig.2.2).

$$\hat{i} \cdot \hat{j} = \hat{j} \cdot \hat{k} = \hat{k} \cdot \hat{i} = 0$$

For ,  $\theta=0^\circ$

$$\vec{A} \cdot \vec{B} = AB \cos \theta = AB \cos 0^\circ = AB \times 1 = AB \quad [\cos 0^\circ = 1]$$

$$\hat{i} \cdot \hat{i} = \hat{j} \cdot \hat{j} = \hat{k} \cdot \hat{k} = 1$$

### (i) Dot product in terms of rectangular component

Let  $A_x, A_y, A_z$  and  $B_x, B_y, B_z$  are the rectangular components of two vectors  $\vec{A}$  and  $\vec{B}$  respectively.

$$\vec{A} = A_x \hat{i} + A_y \hat{j} + A_z \hat{k}$$

$$\vec{B} = B_x \hat{i} + B_y \hat{j} + B_z \hat{k}$$

$$\vec{A} \cdot \vec{B} = (A_x \hat{i} + A_y \hat{j} + A_z \hat{k}) \cdot (B_x \hat{i} + B_y \hat{j} + B_z \hat{k})$$

$$= A_x B_x (\hat{i} \cdot \hat{i}) + A_x B_y (\hat{i} \cdot \hat{j}) + A_x B_z (\hat{i} \cdot \hat{k})$$

$$+ A_y B_x (\hat{j} \cdot \hat{i}) + A_y B_y (\hat{j} \cdot \hat{j}) + A_y B_z (\hat{j} \cdot \hat{k})$$

$$+ A_z B_x (\hat{k} \cdot \hat{i}) + A_z B_y (\hat{k} \cdot \hat{j}) + A_z B_z (\hat{k} \cdot \hat{k})$$

$$= A_x B_x (1) + A_x B_y (0) + A_x B_z (0)$$

$$+ A_y B_x (0) + A_y B_y (1) + A_y B_z (0)$$

$$+ A_z B_x (0) + A_z B_y (0) + A_z B_z (1)$$

$$\Rightarrow \vec{A} \cdot \vec{B} = A_x B_x + A_y B_y + A_z B_z$$

$$\text{Since, } \hat{i} \cdot \hat{j} = \hat{j} \cdot \hat{i} = 0,$$

$$\hat{i} \cdot \hat{k} = \hat{k} \cdot \hat{i} = 0,$$

$$\hat{j} \cdot \hat{k} = \hat{k} \cdot \hat{j} = 0,$$

$$\hat{i} \cdot \hat{i} = \hat{j} \cdot \hat{j} = \hat{k} \cdot \hat{k} = 1$$

Therefore dot product of two vectors is defined as the sum of the product of their rectangular components along the three coordinate axes.

**Problem(1):-** Find the dot product between  $\vec{A} = 3\hat{i} + 2\hat{j} + 5\hat{k}$  and  $\vec{B} = \hat{i} + 3\hat{j} + \hat{k}$

Solution:- Here given  $A_x=3, A_y=2, A_z=5$  and  $B_x=1, B_y=3, B_z=1$

We know that  $\vec{A} \cdot \vec{B} = A_x B_x + A_y B_y + A_z B_z$

$$= 3 \times 1 + 2 \times 3 + 5 \times 1$$

$$= 12+6+35=53$$

**Problem(2):-** Find the dot product between  $A = 2\hat{i} + 5\hat{j} + \hat{k}$  and  $B = 3\hat{i} - \hat{j} + \hat{k}$

Solution:- Here given  $A_x=2, A_y=5, A_z=6$  and  $B_x=3, B_y=-6, B_z=1$

We know that  $\vec{A} \cdot \vec{B} = A_x B_x + A_y B_y + A_z B_z$

$$\begin{aligned} &= 2 \times 3 + 5 \times (-6) + 6 \times 1 \\ &= 6-30+6=-18 \end{aligned}$$

**Problem(3):-** Find the dot product between  $\vec{A} = 5\hat{i} + 2\hat{j} + 3\hat{k}$  and  $\vec{B} = 2\hat{i} - 3\hat{j}$

Solution:- Here given  $A_x=5, A_y=2, A_z=3$  and  $B_x=2, B_y=-3, B_z=0$

We know that  $\vec{A} \cdot \vec{B} = A_x B_x + A_y B_y + A_z B_z$

$$\begin{aligned} &= 5 \times 2 + 2 \times (-3) + 3 \times 0 \\ &= 10-6+0=4 \end{aligned}$$

**Problem(4):-** Find the dot product between  $\vec{A} = \hat{i} + 2\hat{j}$  and  $\vec{B} = 3\hat{i} + 4\hat{j} + \hat{k}$

Solution:- Here given  $A_x=6, A_y=0, A_z=2$  and  $B_x=3, B_y=4, B_z=6$

We know that  $\vec{A} \cdot \vec{B} = A_x B_x + A_y B_y + A_z B_z$

$$\begin{aligned} &= 6 \times 3 + 0 \times 4 + 2 \times 6 \\ &= 18+0+12=30 \end{aligned}$$

**Problem(5):-** Find the dot product between  $A = 3\hat{i} + 2\hat{j}$  and  $\vec{B} = 4\hat{i} + 3\hat{j}$

Solution:- Here given  $A_x=3, A_y=2, A_z=0$  and  $B_x=4, B_y=3, B_z=0$

We know that  $\vec{A} \cdot \vec{B} = A_x B_x + A_y B_y + A_z B_z$

$$\begin{aligned} &= 3 \times 4 + 2 \times 3 + 0 \times 0 \\ &= 12+6+0=18 \end{aligned}$$

### 2.4.2 Cross product or Vector product

Cross product of two vectors  $\vec{A}$  and  $\vec{B}$  defined as a single vector  $\vec{C}$  whose magnitude is equal to the product of their individual magnitude and sine of the smaller angle between them and is directed along the normal to the plane containing  $\vec{A}$  and  $\vec{B}$ .

It is written by putting a cross ( $\times$ ) between two vectors. The resultant of this product possesses a direction. Hence it is also called as vector product.

Consider two vectors  $\vec{A}$  and  $\vec{B}$  drawn from a point and inclined to each other at angle  $\theta$  as shown in the Fig.2.15.

Cross product of  $\vec{A}$  and  $\vec{B}$  is given by

$$\vec{A} \times \vec{B} = \vec{C} = AB \sin \theta \hat{n}$$

Where  $\hat{n}$  is the unit vector of  $\vec{C}$  directed perpendicular to the plane containing  $\vec{A}$  and  $\vec{B}$ .

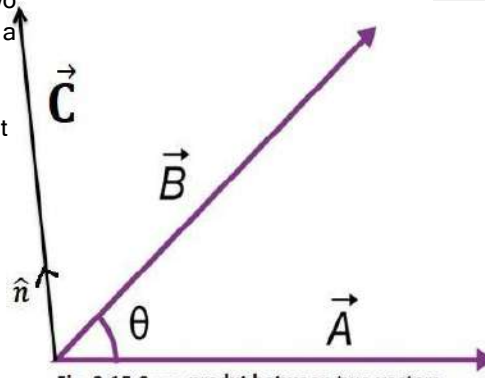

Fig. 2.15 Cross product between two vectors

**Right hand thumb rule:-**

Imagine the normal to the plane (PQRS) containing  $\vec{A}$  and  $\vec{B}$  to be held by your right hand with the thumb erect. If the fingers curl directed from  $\vec{A}$  to  $\vec{B}$  then the direction of the thumb gives the direction of  $\vec{A} \times \vec{B}$

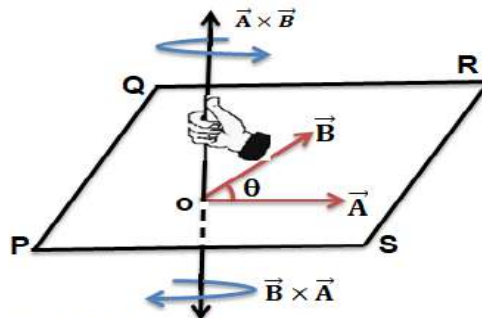

Fig. 2.16 Right hand thumb rule for cross product

For two perpendicular vectors  $\vec{A}$  and  $\vec{B}$ , the angle between them  $\theta=90^\circ$

$$|\vec{A} \times \vec{B}| = AB \sin \theta = AB \sin 90^\circ = (AB)(1) = AB \quad [\sin 90^\circ = 1]$$

$$\Rightarrow |\vec{A} \times \vec{B}| = AB$$

Thus, the magnitude of the cross product of two perpendicular vectors is equal to the product of their individual magnitude.

Since  $\hat{i}$ ,  $\hat{j}$  and  $\hat{k}$  are unit vectors mutually perpendicular to each other (Fig.2.2).

$$\hat{i} \times \hat{j} = \hat{k} \quad \hat{j} \times \hat{i} = -\hat{k}$$

$$\hat{j} \times \hat{k} = \hat{i} \quad \hat{k} \times \hat{j} = -\hat{i}$$

$$\hat{k} \times \hat{i} = \hat{j} \quad \hat{i} \times \hat{k} = -\hat{j}$$

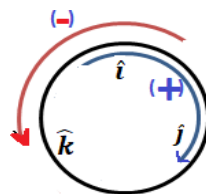

Fig. 2.17 Cyclic Rule

For two parallel vectors  $\vec{A}$  and  $\vec{B}$ , the angle between them  $\theta=0^\circ$

$$\vec{A} \times \vec{B} = AB \sin \theta = AB \sin 0^\circ = (AB)(0) = (0) = \text{null vector}$$

[ $\sin 0^\circ = 0$ ]

Cross product of two equal vectors is always a null vector.

$$\therefore |\vec{i} \times \vec{i}| = |\vec{j} \times \vec{j}| = |\vec{k} \times \vec{k}| = 0$$

### Cross product in terms of rectangular component

Let  $A_x, A_y, A_z$  and  $B_x, B_y, B_z$  are the rectangular components of two vectors  $\vec{A}$  and  $\vec{B}$  respectively.

$$\text{Then } \vec{A} = A_x \hat{i} + A_y \hat{j} + A_z \hat{k}$$

$$\text{And } \vec{B} = B_x \hat{i} + B_y \hat{j} + B_z \hat{k}$$

$$\therefore \vec{A} \times \vec{B} = (A_x \hat{i} + A_y \hat{j} + A_z \hat{k}) \times (B_x \hat{i} + B_y \hat{j} + B_z \hat{k})$$

$$= A_x B_x (\hat{i} \times \hat{i}) + A_x B_y (\hat{i} \times \hat{j}) + A_x B_z (\hat{i} \times \hat{k}) +$$

$$+ A_y B_x (\hat{j} \times \hat{i}) + A_y B_y (\hat{j} \times \hat{j}) + A_y B_z (\hat{j} \times \hat{k}) +$$

$$+ A_z B_x (\hat{k} \times \hat{i}) + A_z B_y (\hat{k} \times \hat{j}) + A_z B_z (\hat{k} \times \hat{k})$$

$$= A_x B_x (0) + A_x B_y (\hat{k}) + A_x B_z (-\hat{j}) + A_y B_x (-\hat{k}) + A_y B_y (0) + A_y B_z (\hat{i}) + A_z B_x (\hat{j}) + A_z B_y (-\hat{i}) + A_z B_z (0)$$

$$\text{Since } \hat{i} \times \hat{j} = \hat{k}, \hat{j} \times \hat{i} = -\hat{k}$$

$$\hat{i} \times \hat{k} = -\hat{j}, \hat{k} \times \hat{i} = \hat{j}$$

$$\hat{j} \times \hat{k} = \hat{i}, \hat{k} \times \hat{j} = -\hat{i}$$

$$|\hat{i} \times \hat{i}| = |\hat{j} \times \hat{j}| = |\hat{k} \times \hat{k}| = 0$$

$$\Rightarrow \vec{A} \times \vec{B} = (A_y B_z - A_z B_y) \hat{i} + (A_z B_x - A_x B_z) \hat{j} + (A_x B_y - A_y B_x) \hat{k}$$

The cross product in terms of rectangular component of two can also be written in the form of determinant, as follows

$$\vec{A} \times \vec{B} = \begin{vmatrix} \hat{i} & \hat{j} & \hat{k} \\ A_x & A_y & A_z \\ B_x & B_y & B_z \end{vmatrix}$$

**Problem(1):-** Find the Cross product between  $\vec{A} = 3\hat{i} + 2\hat{j} + 5\hat{k}$  and  $\vec{B} = 4\hat{i} + 3\hat{j} + \hat{k}$

Solution:- Here given  $A_x=3, A_y=2, A_z=5$  and  $B_x=4, B_y=3, B_z=7$

We know that  $\vec{A} \times \vec{B} = (A_y B_z - A_z B_y)\hat{i} + (A_z B_x - A_x B_z)\hat{j} + (A_x B_y - A_y B_x)\hat{k}$

$$= (2 \times 7 - 5 \times 3)\hat{i} + (5 \times 4 - 3 \times 7)\hat{j} + (3 \times 3 - 2 \times 4)\hat{k}$$

$$= (14 - 15)\hat{i} + (20 - 21)\hat{j} + (9 - 8)\hat{k}$$

$$= -\hat{i} - \hat{j} + \hat{k}$$

**Problem(2):-** Find the cross product between  $\vec{A} = 2\hat{i} + 5\hat{j} + 6\hat{k}$  and  $\vec{B} = 3\hat{i} - 6\hat{j} + \hat{k}$

Solution:- Here given  $A_x=2, A_y=5, A_z=6$  and  $B_x=3, B_y=-6, B_z=1$

We know that  $\vec{A} \times \vec{B} = \begin{vmatrix} \hat{i} & \hat{j} & \hat{k} \\ A_x & A_y & A_z \\ B_x & B_y & B_z \end{vmatrix} = \begin{vmatrix} \hat{i} & \hat{j} & \hat{k} \\ 2 & 5 & 6 \\ 3 & -6 & 1 \end{vmatrix} = \hat{i} \begin{vmatrix} 5 & 6 \\ -6 & 1 \end{vmatrix} - \hat{j} \begin{vmatrix} 2 & 6 \\ 3 & 1 \end{vmatrix} + \hat{k} \begin{vmatrix} 2 & 5 \\ 3 & -6 \end{vmatrix}$

$$= \hat{i}(5 \times 1 - 6 \times (-6)) - \hat{j}(2 \times 1 - 6 \times 3) + \hat{k}(2 \times (-6) - 5 \times 3)$$

$$= \hat{i}(5 + 36) - \hat{j}(2 - 18) + \hat{k}(-12 - 15)$$

$$= \hat{i}(41) - \hat{j}(-16) + \hat{k}(-27)$$

$$= 41\hat{i} + 16\hat{j} - 27\hat{k}$$

# EXERCISE

## VERY SHORT ANSWER QUESTIONS(2 Marks each)

1. Define Scalar and Vector Quantity? Give one example of each of them.
2. State the characteristics of null vector.
3. State the triangle law of vector addition.
4. Define coplanar vector.

5. Find the dot product between  $A = 3\hat{i} + 2\hat{j} + 3\hat{k}$  and  $\bar{B} = 5\hat{i} - 3\hat{j}$   
 [Ans. Here given  $A_x=3, A_y=2, A_z=3$  and  $B_x=5, B_y=-3, B_z=0$

$$\begin{aligned} \text{We know that } \bar{A} \cdot \bar{B} &= A_x B_x + A_y B_y + A_z B_z \\ &= 3 \times 5 + 2 \times (-3) + 3 \times 0 = 15 - 6 + 0 = 9 \end{aligned}$$

6. Find the dot product between  $A = 5\hat{i} + 6\hat{j} + \hat{k}$  and  $\bar{B} = 2\hat{i} + 3\hat{j}$

[Ans. Here given  $A_x=5, A_y=6, A_z=1$  and  $B_x=2, B_y=3, B_z=0$

$$\begin{aligned} \text{We know that } \bar{A} \cdot \bar{B} &= A_x B_x + A_y B_y + A_z B_z \\ &= 5 \times 2 + 6 \times 3 + 1 \times 0 \\ &= 10 + 18 + 0 = 28 \end{aligned}$$

## SHORT ANSWER QUESTIONS (5 Marks each)

1. State and explain triangle law of vector addition.
2. State and explain Parallelogram law of vector addition.
3. Find the Cross product between  $\bar{A} = 2\hat{i} + 4\hat{j} + 3\hat{k}$  and  $\bar{B} = 4\hat{i} + 6\hat{j} + 7\hat{k}$

[Ans. Here given  $A_x=2, A_y=4, A_z=3$  and  $B_x=4, B_y=6, B_z=7$

$$\begin{aligned} \text{We know that } \bar{A} \times \bar{B} &= \begin{vmatrix} \hat{i} & \hat{j} & \hat{k} \\ A_x & A_y & A_z \\ B_x & B_y & B_z \end{vmatrix} = \begin{vmatrix} \hat{i} & \hat{j} & \hat{k} \\ 2 & 4 & 3 \\ 4 & 6 & 7 \end{vmatrix} = \hat{i} \begin{vmatrix} 4 & 3 \\ 6 & 7 \end{vmatrix} - \hat{j} \begin{vmatrix} 2 & 3 \\ 4 & 7 \end{vmatrix} + \hat{k} \begin{vmatrix} 2 & 4 \\ 4 & 6 \end{vmatrix} \end{aligned}$$

$$\begin{aligned} &= \hat{i}(4 \times 7 - 3 \times 6) - \hat{j}(2 \times 7 - 3 \times 4) + \hat{k}(2 \times 6 - 4 \times 4) \\ &= \hat{i}(28 - 18) - \hat{j}(14 - 12) + \hat{k}(12 - 16) \\ &= \hat{i}(10) - \hat{j}(2) + \hat{k}(-4) = 10\hat{i} + 2\hat{j} - 4\hat{k} \end{aligned}$$

4. Drive the resolution of a vector on horizontal and vertical components.

5. Find the Cross product between  $\bar{A} = 3\hat{i} + 2\hat{j}$  and  $\bar{B} = 4\hat{i} + 7\hat{j}$

[Ans. Here given  $A_x=3, A_y=2, A_z=0$  and  $B_x=4, B_y=7, B_z=0$

$$\begin{aligned} \text{We know that } \bar{A} \times \bar{B} &= \begin{vmatrix} \hat{i} & \hat{j} & \hat{k} \\ A_x & A_y & A_z \\ B_x & B_y & B_z \end{vmatrix} = \begin{vmatrix} \hat{i} & \hat{j} & \hat{k} \\ 3 & 2 & 0 \\ 4 & 7 & 0 \end{vmatrix} = \hat{i} \begin{vmatrix} 2 & 0 \\ 7 & 0 \end{vmatrix} - \hat{j} \begin{vmatrix} 3 & 0 \\ 4 & 0 \end{vmatrix} + \hat{k} \begin{vmatrix} 3 & 2 \\ 4 & 7 \end{vmatrix} \end{aligned}$$

$$\begin{aligned} &= \hat{i}(2 \times 0 - 0 \times 7) - \hat{j}(3 \times 0 - 0 \times 4) + \hat{k}(3 \times 7 - 2 \times 4) \\ &= \hat{i}(0 - 0) - \hat{j}(0 - 0) + \hat{k}(21 - 8) = \hat{i}(0) - \hat{j}(0) + \hat{k}(13) = 13\hat{k} \end{aligned}$$

## LONG ANSWER QUESTIONS (10 Marks each)

1. Explain different types of vectors with diagram..

## UNIT 3

### KINEMATICS

Motion is common to everything in the universe. We walk, run, and ride a bicycle. Even when we are sleeping, air moves into and out of our lungs and blood flows in arteries and veins. We see leaves falling from trees and water flowing down a dam. Automobiles and planes carry people from one place to the other. Motion is change in position of an object with time. In this chapter we are going to discuss basic concept of kinematics (i.e., study of motion of bodies without the consideration of the force involved).

#### 3.1.1 Rest

A body is said to be at rest when it does not change its position with respect to the surrounding or a specified reference frame.

The position of a body can be specified by its projections on the three axes of a rectangular co-ordinate system having its origin O at a fixed point. Distances of these projections from O are called as Position co-ordinates. If the co-ordinates do not change with time, the body is said to be at rest.

#### 3.1.2 Motion

A body is said to be in motion if it changes its position with respect to the surroundings or a specified reference frame.

As the body moves along any path in space, its projections move in straight line along the three axes. The actual motion can be reconstructed from the motion of these three projections.

#### 3.2.1 Displacement

Displacement is a vector connecting between the initial and final position of the body and directed away from the initial position towards the final position.

The shortest distance between initial and final position of the body is called as displacement.

Displacement can be represented as “s” and dimensional formula is  $s = [M^0L^1T^0]$  and its SI unit is Metre (m).

#### 3.2.2 Speed

Speed of a body is defined as the distance travelled by the body in unit time.

$$\text{Speed} = \frac{\text{Distance}}{\text{Time}} = \frac{s}{t}$$

Dimensional formula of speed is  $[M^0L^1T^{-1}]$  and SI unit is Metre/ Second (m/s).

#### 3.2.3 Velocity (v)

Velocity of a body is defined as the rate of change of displacement of the body.

$$\text{Average velocity } (\bar{v}_{av}) = \frac{\text{Total Displacement}}{\text{Total Time}} = \frac{\Delta s}{\Delta t}$$

The velocity at a particular instant of time is called as instantaneous velocity.

$$\text{Instantaneous velocity } (\bar{v}) = \frac{ds}{dt}$$

Dimensional formula of velocity is  $[M^0L^1T^{-1}]$  and SI unit is Metre/ Second (m/s).

### 3.2.4 Acceleration (a)

Acceleration is defined as the rate of change of velocity of a body.

$$\text{Acceleration } (\bar{a}) = \frac{\text{Change in Velocity}}{\text{Change in time}}$$

$$\Rightarrow \bar{a} = \frac{dv}{dt} = \frac{d(\frac{ds}{dt})}{dt} \quad ; \quad \bar{v} = \frac{ds}{dt}$$

$$\Rightarrow \bar{a} = \frac{d^2s}{dt^2}$$

Dimensional formula of acceleration is  $[M^0L^1T^{-2}]$  and SI unit is  $m/s^2$  or  $ms^{-2}$

### 3.2.5 Force (F)

Force is an external agent capable of changing the state of rest or motion of a body.

Force (F) = mass × acceleration

$$\Rightarrow F = m\bar{a}$$

$$\Rightarrow F = m \frac{dv}{dt}$$

Dimensional formula of Force,  $F = ma = [M^1][L^1T^{-2}] = [M^1L^1T^{-2}]$

And SI unit is  $kg\ m/s^2$  or Newton

### 3.3.1 Equations of Motion under Gravity (downward motion)

Consider a body falling freely from a point „O“ with initial velocity  $u = 0$ . It reaches a point „P“ after „t“ second and acquires a velocity „v“ due to the uniform acceleration due to the gravity „g“. Here „v“ is called as final velocity just before hitting the ground. It covers a distance „h“ while moving from „O“ to „P“.

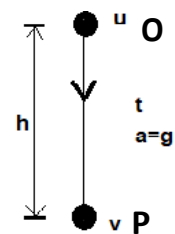

Fig. 3.1 Body fall from a height

Therefore, the equations of motion under gravity in downward motion can be written as follows:

For downward motion under gravity,  $a = g$

- |                                   |   |
|-----------------------------------|---|
| 1. Velocity time relation         | $v = u + at = u + gt$                             |
| 2. Displacement time relation     | $h = ut + \frac{1}{2}at^2 = ut + \frac{1}{2}gt^2$ |
| 3. Velocity displacement relation | $v^2 = u^2 + 2gh = u^2 + 2gh$                     |
| 4. Displacement in „nth“ second   | $S_{nth} = u + \frac{g}{2}(2n - 1)$               |

For a freely falling body,  $u = 0$

Hence,  $h = \frac{1}{2}gt^2$

$$t = \sqrt{\frac{2h}{g}}$$

This is the time of descent. It can be seen that this does not depend on the mass of falling object provided air resistance is neglected.

### 3.3.2 Equations of Motion under Gravity (upward):

Consider a body thrown upward from a point „O“ with initial velocity „u“ at time  $t=0$  (Fig. 3.2). It reaches a point „P“ after „t“ second and acquires a velocity „v“ due to the uniform acceleration due to the gravity „g“. Here „v“ is called as final velocity after travelling a height h.

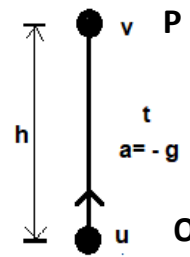

Fig. 3.2 a body is thrown in to a height

The equations of motion under gravity in upward motion can be written as follows:

For upward motion under gravity,  $a = -g$

- |                                   |   |
|-----------------------------------|---|
| 1. Velocity time relation         | $v = u + at = u - gt$   |
| 2. Displacement time relation     | $h = ut + \frac{1}{2}at^2 = ut - \frac{1}{2}gt^2$             |
| 3. Velocity displacement relation | $v^2 = u^2 + 2gh = u^2 - 2gh$                                 |
| 4. Displacement in „nth“ second   | $S_{nth} = u + \frac{g}{2}(2n - 1) = u - \frac{g}{2}(2n - 1)$ |

At maximum height,  $v = 0$ , so,  $t = \frac{u}{g}$ . This is the time of ascent.

$$\text{Hence, } h = ut - \frac{1}{2}gt^2 = \frac{u^2}{g} \equiv \frac{u^2}{2g}$$

This is the maximum height reached by the object when thrown with an initial velocity of  $u$ .

### 3.4 Circular motion

A body is said to move in circular motion, if it moves in such a way that its distance from a fixed point always remains constant.

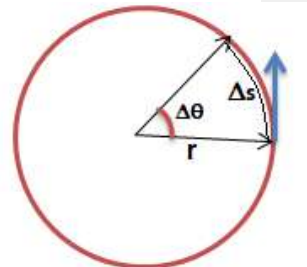

**Fig. 3.3 Circular motion**

#### 3.4.1 Angular Displacement ( $\Delta\theta$ )

Angular Displacement of a body undergoing circular motion is defined as the angle turned by its radius vector.

It is a vector quantity. It acts along the axis of rotation as per the right hand thumb rule.

$$\Delta\theta = \frac{\Delta s}{r}$$

Here angular displacement is dimensionless quantity  $[M^0L^0T^0]$  and its SI unit is radian (rad).

#### 3.4.2 Angular Velocity ( $\omega$ )

Angular velocity of a body undergoing circular motion is defined as the rate of change of angular displacement with time.

It is a vector quantity and act along the axis of rotation i.e. along the same direction as displacement vector.

$$\omega = \frac{d\theta}{dt}$$

Here dimensional formula of angular velocity is  $[M^0L^0T^{-1}]$  and its SI unit is radian per second (rad/s).

#### 3.4.3 Angular acceleration ( $\alpha$ )

Angular acceleration of a body undergoing circular motion is defined as the rate of change of angular velocity with time.

It is a vector quantity and acts along the axis of rotation.

$$\alpha = \frac{d\omega}{dt}$$

Here dimensional formula of angular acceleration is  $[M^0L^0T^{-2}]$  and its SI unit is radian per second<sup>2</sup> (rad/s<sup>2</sup>).

### 3.5.1 Relation between Linear displacement( $\Delta s$ ) and Angular Displacement ( $\Delta\theta$ ):-

$$\text{We know that } \Delta\theta = \frac{\Delta s}{r}$$

$\Rightarrow \Delta s = r \Delta \theta$ , this is the scalar form.

In vector form, Linear Displacement =  $d\vec{s} = \vec{d\theta} \times \vec{r}$

### 3.5.2 Relation between Linear velocity (v) and Angular velocity ( $\omega$ ):-

We know that the angular velocity,

$$\omega = \frac{d\theta}{dt}$$

$$\Rightarrow \omega = \frac{\theta}{dt} = \frac{1}{r} \frac{ds}{dt} \quad ; d\theta = ds/r$$

$$\Rightarrow \omega = \frac{1}{r} v \quad ; v = \frac{ds}{dt}$$

$\Rightarrow v = r\omega$ , this is linear speed (scalar form).

In vector form,  $\vec{v} = \vec{\omega} \times \vec{r}$

### 3.5.3 Relation between Linear acceleration (a) and Angular acceleration ( $\alpha$ ):-

We know that the angular acceleration,

$$\alpha = \frac{d\omega}{dt}$$

$$\Rightarrow \alpha = \frac{\omega}{dt} = \frac{1}{r} \frac{dv}{dt} \quad ; \omega = v/r$$

$$\Rightarrow \alpha = \frac{1}{r} a \quad ; a = \frac{dv}{dt}$$

$\Rightarrow a = r \alpha$ , This is linear acceleration or tangential acceleration.

In vector form  $\vec{a} = \vec{\alpha} \times \vec{r}$

**Example (1):-** A car goes round a curve path, of radius 8 m, with a velocity  $54 \text{ km h}^{-1}$ .  
What is its angular velocity?

**Answer:-** Given velocity,  $v = 54 \text{ km h}^{-1} = 54 \times \frac{5}{18} \text{ m s}^{-1} = 15 \text{ m s}^{-1}$

and  $r = 8 \text{ m}$

We know that,  $v = r\omega$

$$\Rightarrow 15 = 8 \omega$$

$$\Rightarrow \omega = \frac{15}{8} \text{ rad s}^{-1} = 1.875 \text{ rad s}^{-1}$$

**Example (2):-** A particle moving in a circle of radius 10 m has its angular velocity increased, in one minute, by  $90 \text{ rad min}^{-1}$ . Calculate

- (i) Angular acceleration
- (ii) Tangential or linear acceleration.

**Answer:-** Here given

$$\text{Change in angular velocity} = 90 \text{ rad min}^{-1} = \frac{90}{60} \text{ rad s}^{-1} = 1.5 \text{ rad s}^{-1}$$

and time = 60 s, radius  $r = 10 \text{ m}$

$$(i) \text{ Angular acceleration, } a = \frac{\text{Change in angular velocity}}{\text{time}} = \frac{1.5}{60} \text{ rad s}^{-2} = \frac{1}{40} \text{ rad s}^{-2}$$

$$(ii) \text{ Linear acceleration, } a = r a = 10 \times \frac{1}{40} \text{ m s}^{-2} = 0.25 \text{ m s}^{-2}$$

### 3.6 Projectile motion

Projectile is a body thrown with an initial velocity in the vertical plane and then it moves in two dimensions under the action of gravity alone without being propelled by any engine or fuel.

The path of projectile is called its trajectory.

Example:-

- (i) A cricket ball thrown into the space.
- (ii) A fruit falling from a tree.
- (iii) A bullet fired from a rifle.
- (iv) A bag dropping from an aeroplane.
- (v) A football kicked into the space.

### 3.7 Projectile fired at an angle $\theta$ with the horizontal.

Consider a projectile fired from a point O with a velocity „u” at an angle  $\theta$  with horizontal. The projectile rises to the maximum height „H” at point P and fall back at Q, lying on the same level of projection (Fig. 3.4).

Since the projectile moves in X-Y plane, so velocity „u” can be resolved in to two components as follows.

- (i)  $u \cos\theta$  along horizontal direction. This component is uniform since it does not depend upon acceleration due to gravity „g”.

- (ii)  $u \sin\theta$  along vertical direction. This component is non-uniform since the acceleration due to gravity ( $g$ ) acts exactly opposite to it. It is zero at the maximum height.

The above mentioned two components are independent to each other, since they are mutually perpendicular.

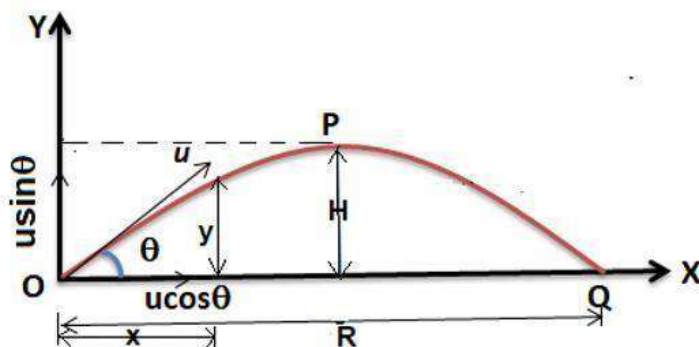

Fig. 3.4 Projectile fired at an angle  $\theta$  with horizontal

The following important results can be derived in this case.

### 3.7.1 Equation of trajectory

It is an equation which connects between horizontal displacement and vertical displacement of the projectile motion.

Applying equation of motion,  $s = ut + \frac{1}{2}at^2$  ----- (1)

along horizontal direction we get,

$$x = u \cos\theta t + \frac{1}{2} \times 0 \times t^2$$

Here, horizontal direction,  $s =$  horizontal displacement  $= x$ ,  
 $u =$  horizontal displacement  $= u \cos\theta$   
 $a =$  horizontal acceleration  $= g = 0$

**Hence,**  $x = u \cos\theta t$

$$\Rightarrow t = \frac{x}{u \cos\theta} \text{-----(2)}$$

Applying equation of motion,  $s = ut + \frac{1}{2}at^2$ ----- (3)

along the vertical direction, we get

$s =$  vertical displacement  $= y$   
 $u =$  Initial vertical velocity  $= u \sin\theta$   
 $a =$  acceleration due to gravity  $= -g$

Therefore, from the above equation (3), we can write

$$y = u \sin \theta t + \frac{1}{2}(-g)t^2$$

$$y = u \sin \theta t - \frac{1}{2}gt^2 \text{ ----- (4)}$$

Now putting the value of equation (2) in equation (4), we get

$$y = u \sin \theta \frac{x}{u \cos \theta} - \frac{1}{2}g\left(\frac{x}{u \cos \theta}\right)^2$$

$$\Rightarrow y = x \tan \theta - \frac{gx^2}{2u^2 \cos^2 \theta} \text{ (5)}$$

This equation is known as equation of trajectory. Since equation (5) satisfies the equation of parabola, so the path of the projectile is parabolic.

### 3.7.2 Maximum height (H)

It is the maximum distance travelled by the projectile in vertical direction. It is travelled due to vertical component of velocity.

Applying equation of motion,

$$v^2 - u^2 = 2as \text{ ----- (6)}$$

Here we have considered the motion of projectile in the vertical direction, so we can write:

- s = maximum height = H
- u = Initial vertical velocity =  $u \sin \theta$
- v = final vertical velocity at the highest point = 0
- a = acceleration due to gravity = -g

Therefore, from the above equation (6), we get:

$$0^2 - u^2 \sin^2 \theta = 2(-g)H$$

$$\Rightarrow u^2 \sin^2 \theta = 2gH$$

$$\Rightarrow H = \frac{u^2 \sin^2 \theta}{2g} \text{ ----- (7)}$$

### 3.7.3 Time of ascent (t)

It is time taken by the projectile to reach the maximum height from the point of projection.

Applying equation of motion,

$$v = u + at \text{ ----- (8)}$$

Here we have considered the motion of projectile from „O“ to „P“ in the vertical direction only, so we can write:

- u = Initial vertical velocity =  $u \sin \theta$
- v = final vertical velocity at the highest point = 0
- a = acceleration due to gravity = -g
- t = time of ascent

Therefore, from the above equation (8), we get:

$$0 = u \sin \theta + (-g)t$$

$$\Rightarrow gt = u \sin \theta$$

$$\Rightarrow t = \frac{u \sin \theta}{g} \dots \dots \dots (9)$$

The above equation represents the time of ascent of the projectile.

**3.7.4 Time of descent (t)**

It is time taken by the projectile to reach the level of projection from the maximum height.

**3.7.5 Total time of flight (T)**

It is total time taken by the projectile to come back to the ground from which it was projected.

If the air resistance is neglected, then time of descent is equal to the time of ascent =t.

Therefore,

$$\text{Total time of flight}(T) = \text{time of ascent}(t) + \text{time of descent}(t)$$

$$\Rightarrow T = \frac{u \sin \theta}{g} + \frac{u \sin \theta}{g}$$

$$\Rightarrow T = \frac{2u \sin \theta}{g} \dots \dots \dots (10)$$

**3.7.6 Horizontal range (R)**

It is the distance travelled by the projectile in the horizontal direction during its time of flight. The horizontal range is travelled due to the horizontal component of velocity which is uniform.

$$R = \text{horizontal velocity} \times \text{Total time of flight}$$

$$\Rightarrow R = u \cos \theta \times \frac{2u \sin \theta}{g}$$

$$\Rightarrow R = \frac{u^2 2 \sin \theta \cos \theta}{g}$$

$$\Rightarrow R = \frac{u^2 \sin 2\theta}{g} \dots\dots\dots(11) [\sin 2\theta = 2 \sin \theta \cos \theta]$$

### 3.7.7 Condition for maximum Horizontal range ( $R_{max}$ )

We know that the horizontal range of projectile motion is

$$R = \frac{u^2 \sin 2\theta}{g}$$

It is clear that horizontal range depends upon the value of velocity of projection „u“ and angle of projection „ $\theta$ “. For fixed value of „u“, horizontal range depends upon the angle of projection „ $\theta$ “. Horizontal range will be maximum if „ $\sin 2\theta$ “ is maximum. *i.e.*,

$$\sin 2\theta = 1$$

$$\Rightarrow \sin 2\theta = \sin 90^\circ$$

$$\Rightarrow 2\theta = 90^\circ$$

$$\Rightarrow \theta = 45^\circ$$

This is the condition for maximum horizontal range. Maximum horizontal range can be written as

$$R_{max} = \frac{u^2 \times 1}{g}$$

$$\Rightarrow R_{max} = \frac{u^2}{g} \dots\dots\dots(12)$$

This is the maximum horizontal range travelled by the projectile fired at an angle  $\theta=45^\circ$ .

# EXERCISE

## VERY SHORT ANSWER QUESTIONS(2 Marks each)

1. Define rest and motion.
2. Distinguish between distance and displacement.
3. How do you define acceleration? State the unit in which it is measured.
4. What do you mean by horizontal range? Under what condition it is maximum?
5. A body starts from rest and covers a distance by acquiring a velocity of 20m/s in 5 sec. Find the acceleration. [Ans.  $4\text{m/s}^2$ ]
6. A body covers a distance of 50m along a straight line in 5 sec. Calculate the speed at the end of 5 sec? [Ans. 10m/s]
7. Explain the circumstances in which a body has zero average velocity.

### [ Answer

Average velocity = Net displacement/time taken

Suppose a car covers a distance of 50 m in 5 seconds and comes back to initial position in 5 seconds. The average speed of car is 10 m/s, but average velocity is zero because displacement is zero.

A body is moving in a circular path and complete one rotation. So, the total displacement is zero. Therefore, average velocity is zero.

## SHORT ANSWER QUESTIONS (5 Marks each)

1. Find the relationship between linear velocity and angular velocity.
2. Write short notes on (i) Velocity, (ii) Acceleration, (iii) Displacement
3. Find the relation between linear acceleration and angular acceleration.
4. A body starting from rest moves with an acceleration of  $5\text{ m/s}^2$ . Calculate its velocity when it covered a distance of 20m. [ Ans.  $14\text{m/s}$ ]
5. A body possessing an initial velocity of 10m/s moves an acceleration  $2\text{m/s}^2$ . Calculate its velocity at the end of 4 sec. [Ans.  $18\text{m/s}$ ]
6. Show that the path of a projectile fired at an angle „ $\theta$ “ with horizontal is parabolic in nature.

## LONG ANSWER QUESTIONS (10 Marks each)

1. A projectile is fired with a velocity „ $u$ “ with making an angle „ $\theta$ “ with horizontal. Find the following expressions
  - (i) Equation of trajectory
  - (ii) Maximum height attained
  - (iii) Time of ascent
  - (iv) Total time of flight
  - (v) Horizontal range
  - (vi) Condition for maximum horizontal range.

2. A body travels along a circular path of radius 10m. It completes half of circumference in three sec. Calculate its (i) Distance covered, (ii) displacement, (iii) speed and (iv) velocity.

[Ans. (i)31.4m, (ii)20m (iii)10.466m/s, and (iv)6.666m/s

## UNIT 4

### WORK AND FRICTION

#### 4.1 WORK:

Work is said to be done if the force applied on a body displaces the body and the force has a component along the direction of displacement. Work is a scalar quantity and is the dot product of two vectors Force and Displacement.

$$W = \vec{F} \cdot \vec{s} = F s \cos \theta$$

Where, W = work done

F = magnitude of the force

s = magnitude of the displacement

$\theta$  = angle between the force and displacement

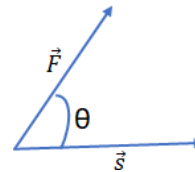

Figure 4.1

- If,  $\theta = 0^\circ$ , then  $W = F s \cos 0^\circ = +Fs$ .

Here, Force and Displacement are in the same direction and work done is *positive*, which means work is said to be done *upon* the body.

Example: An object falling freely under the action of gravity, Kicking a football, A car moving forward etc

- If  $\theta = 90^\circ$ , then  $W = F s \cos 90^\circ = 0$ ,

Here, Force and Displacement are perpendicular to each other and no work is done.

Example: A person carrying a box over his head and walking in the horizontal direction. In this case, *work done by the force of gravity is zero*.

- If  $\theta = 180^\circ$ , then  $W = F s \cos 180^\circ = -Fs$ .

Here, Force and Displacement are in the opposite direction and *Negative* work is done means work is done *by* the body.

Example: Work done by the force of friction is negative. Pushing a car up a hill, when it is sliding down, Brakes applied to a moving car, Object pulled over a rough horizontal surface etc.

- When the force is applied without any displacement, then also work done is zero.

$$W = F \times 0 = 0$$

Example: A person sitting on a chair and studying a book, Pushing a wall etc

**Unit:**

The SI unit of work is Joule (J) and the CGS unit is Erg.

The SI unit and dimensions of work and energy are same.

**Dimension:**

$$[W] = [F][s][\cos\theta] = MLT^{-2} \times L = ML^2T^{-2}$$

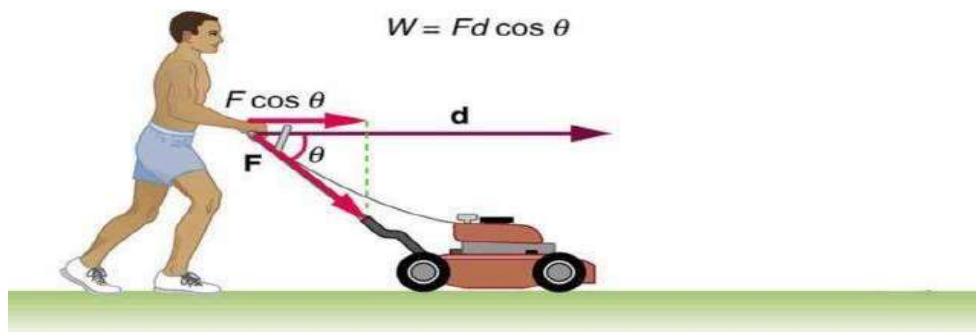

(a)

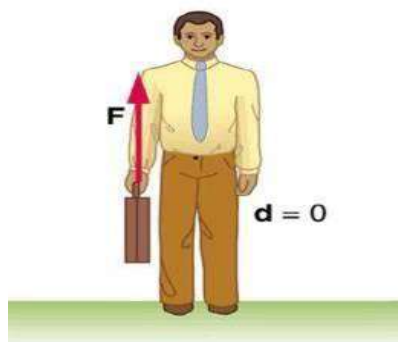

(b)

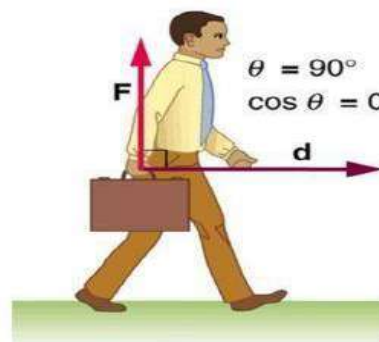

(c)

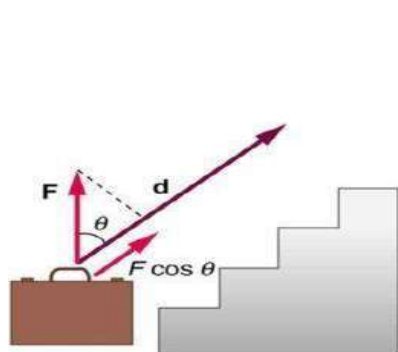

(d)

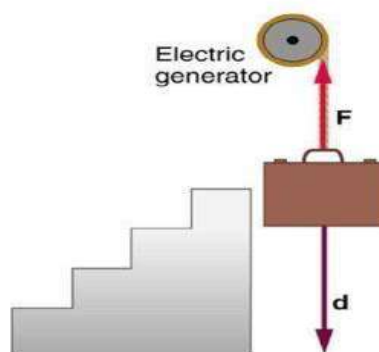

(e)

Examples of work. (a) Positive work-The work done by the force on this lawn mower is  $Fd \cos \theta$ . Here  $\cos \theta$ , the component of the force is in the direction of motion. (b) Zero work- A person holding a briefcase does no work on it, because

there is no motion. (c) Zero work- The person moving the briefcase horizontally at a constant speed does no work on it, as Force and Displacement act Perpendicular to each other. (d) Positive work- Work is done on the briefcase by carrying it up stairs at constant speed, because there is a component of force  $F$  in the direction of the motion. (e) Negative Work- Here the work done on the briefcase by the generator is negative, because  $F$  and  $d$  are in opposite directions.

## 4.2 FRICTION:

Let us say there is an *almirah* placed on the *floor*. One person tries to push it. He exerts force, the almirah does not move in the beginning. Then, the person increases force little by little and at one point the almirah starts to move.

Let us analyse this situation. When the person is applying force, the force must have some effect (the force must create acceleration). But *apparently* there is no effect. Why is it happening? It is because when the person is applying force, the *floor* is exerting an equal amount of force on the almirah. Hence, the effect of force is getting cancelled. When the person is increasing the force, the force on the almirah by the floor is increasing too. However, there is a *limit* to the force by the floor. Once, it is reached, the almirah starts to move. However, when the almirah is moving, the floor is still applying force on the almirah. The force tries to oppose the motion of the almirah. In this example, the force on the almirah by the floor arising because of the contact between them is *frictional force*.

In this chapter, we will formally discuss the concept of friction, the types of friction and the laws regarding friction.

### Definition:

**The force which opposes or tend to oppose the relative motion between two surfaces in contact is called as force of friction.**

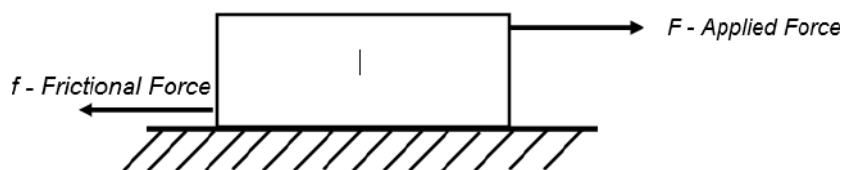

Figure 4.2

Force of friction is created because of the inter-locking of two surfaces in contact.

### 4.2 TYPES OF FRICTION:

Friction can be classified into four types.

1. Static Friction- Static Friction is the opposing force exists between a surface and object at rest. Example- A book on a table.

2. Kinetic (dynamic) friction-Dynamic Friction is the opposing force created when two solid surfaces slide/ move over one another. Example- writing on paper or pushing a chair across the floor. Walking on the road.
3. Rolling friction - Rolling friction is the opposing force created between moving surfaces when one rolls over another. Example- Car moving on road, Rolling a ball down the lane
4. Fluid friction (viscosity)- Fluid friction is the opposing force created when something tries to move on or through the gas or liquid. Example- Pushing up water backward while Swimming.

In this chapter we will focus on static and dynamic friction and the laws regarding them.

**1. Static Friction:**

- The force of friction which comes into play when there is no relative motion between two surfaces in contact is called as force of static friction. Force of static friction is equal and opposite to the applied force till the body is at rest.
- For example, a person or a group of persons are trying to push a heavy object. Initially, a small force is applied, and the magnitude of force is increased gradually. The magnitude of static friction increases gradually too. As long as the object is in static condition, the floor exerts an equal and opposite force on the object. As in the below figure, the applied force is towards the right, hence the frictional force is towards the left.

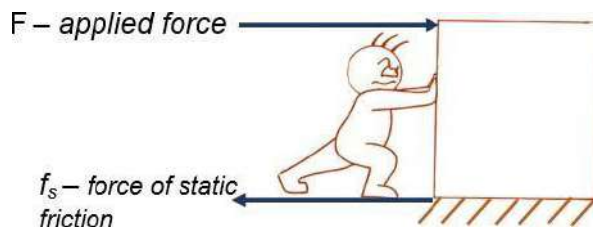

Figure 4.3

- Static friction is a self-adjusting force.
- The maximum value of static friction is called the **limiting friction**.

$$f_L = \mu_s R \dots\dots\dots(1)$$

Where,  $f_L$  – force of limiting friction  
 $\mu_s$  – coefficient of static friction  
 $R$  – Normal reaction

Once the limiting friction is reached, the body starts to move, and kinetic friction comes to picture.

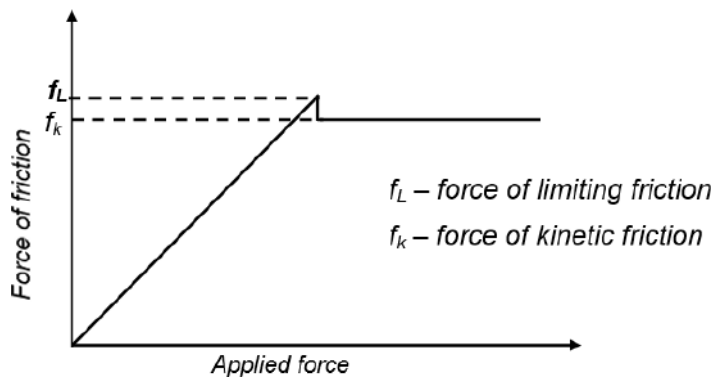

Figure 4.4

## 2. Kinetic (dynamic) Friction:

The force of friction, which comes into play when there is relative motion between two surfaces in contact is called as force of kinetic friction or dynamic friction or sliding friction. The direction of the frictional force is always opposite to the direction of motion, for which the relative slipping is opposed by the friction.

$$\text{Hence, } f_k = \mu_k R \text{ -----(2)}$$

Where,  $f_k$  – force of kinetic friction  
 $\mu_k$  – coefficient of kinetic friction  
 $R$  – Normal reaction

### 4.4. LAWS OF LIMITING FRICTION:

Statements about factors upon which the force of limiting friction between two surfaces depends, are termed as laws of limiting friction. They are stated as below.

- i. The direction of force of friction is always opposite to the direction of motion.
- ii. The force of limiting friction depends on the nature and state of polish of the surfaces in contact and act tangentially to the interface between the two surfaces.
- iii. The magnitude of limiting friction  $f_L$  is directly proportional to the magnitude of the normal reaction  $R$  between the two surfaces in contact.

$$f_L \propto R$$

- iv. The magnitude of the limiting friction between two surfaces is independent of the area and shape of the surfaces in contact as long as the normal reaction remains same.

### 4.5. COEFFICIENT OF FRICTION

- The frictional force ( $f$ ) is directly proportional to the normal reaction force ( $R$ ) and the proportionality constant  $\mu$  is called the coefficient of friction.

$$\mu = \frac{f}{R}$$

- Hence, the coefficient of friction is defined as the ratio of the friction force to the normal force.
- The coefficient of friction is determined experimentally.
- As the unit and dimension of frictional force and normal force are same,  $\mu$  is unit and dimensionless.
- The coefficient of friction depends on the nature of the bodies in contact, their material and the surface roughness.

**Example 1:**

A box of mass 30 kg is pulled on a horizontal surface by applying a horizontal force. If the coefficient of dynamic friction between the box and the horizontal surface is 0.25, find the force of friction exerted by the horizontal surface on the box.

**Answer:**

Mass  $m = 30 \text{ kg}$ ,  $\mu = 0.25$   
Normal Reaction  $R = mg$

$$f_k = \mu_k R \Rightarrow = \mu_k mg = 0.25 \times 30 \times 9.8 = 73.5 \text{ Newton}$$

**Example 2:**

A body of mass 10 kg is placed on a rough horizontal surface at rest. The coefficient of friction between the body and the surface is  $\mu = 0.1$ . Find the force of friction acting on the body.

**Answer:**

Since, the body is at rest, the force of static friction will come into play which is equal to applied force.

Since, applied force is zero, the force of static friction is zero.

**Example 3:**

Find the force of friction in situation as shown in the below figure. Take  $g = 10 \text{ m/s}^2$

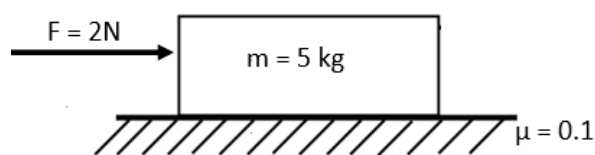

Figure 4.5

**Answer:**

The magnitude of limiting friction  $f_L = \mu R = 0.1 \times 5g = 5 \text{ N}$

We see, the applied force is smaller than the force of limiting friction i.e.,  $F < F_L$

So, the force of static friction = magnitude of applied force = 2 N.

#### 4.6 METHODS TO REDUCE FRICTION:

The following methods can be used to reduce friction when friction creates hurdle in the performance of machines or for similar necessary reasons

i. **By polishing or rubbing:**

The roughness of a surface can be reduced by rubbing or polishing it. The polishing makes a surface smooth and reduces friction.

ii. **Lubrication or use of talcum powder:**

Friction can be reduced by using lubricants like oil and grease or talcum powder as they form a thin film between different parts of a machine. This film covers up the pores & the lumps present on the surfaces of different parts, and hence improves the smoothness.



iii. **By converting sliding friction to rolling friction:**

Rolling friction is lesser than sliding friction. Hence, ball bearings can be placed between the moving parts of a machine to avoid direct contact between them. This reduces friction.

Ball Bearings in a Wheel

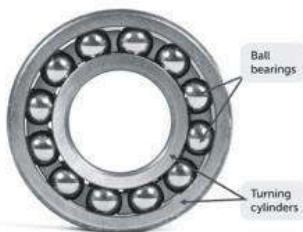

iv. **Streamlining:**

The objects that move in fluid, for example, bullet train, ship, boat or aeroplane, the shape of the body can be streamlined to reduce the friction between the body and the fluid.

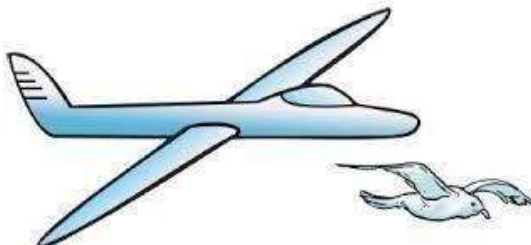

## **EXERCISE**

### **I. Very short type questions (2 marks each)**

1. Define work. Write its formula and unit.
2. Define friction.
3. Define limiting friction. Write its formula.
4. Define coefficient of friction. State its unit and dimension

### **II. Short type questions (5 marks each)**

1. Define limiting friction. State the laws of limiting friction.
2. Write five methods to reduce friction

### **III. Long type questions (10 marks each)**

1. Compare static and kinetic friction. State the laws of limiting friction.
2. Define friction and coefficient of friction. What are the methods to reduce friction?

## UNIT 5

# GRAVITATION

We throw a ball upward, it goes to a certain height, then it comes back towards the earth. The ripened fruit of a tree comes down in a straight line. The fruit does not go side wise or diagonally. So, the question is what makes these objects fall. Is there something which is pulling the fruit? Is it earth that is pulling? Now, again the question is if earth can pull a fruit, can it pull the moon too? So, in a sentence, is the nature of force acting between the earth and moon and that between earth and fruit same? Thinkers, philosophers, scientists have pondered over these questions deeply and have gifted us with simplified ideas about the laws of nature. In this chapter we will discuss the basic and fundamental classical laws in the field of gravitation.

### 5.1. Newton's Laws of gravitation:

Each body in the universe attracts every other body with a force which is directly proportional to the product of their masses and inversely proportional to the square of the distance between them.

Let  $m_1$  and  $m_2$  be the masses of two point-objects and the distance between them be  $r$ .

Then,  $F \propto m_1 m_2$

$$\Rightarrow F = G \frac{m_1 m_2}{r^2} \dots \dots \dots (1)$$

Where,  $G$  = universal gravitational constant =  $6.67 \times 10^{-11} \text{Newton } m^2 kg^{-2}$

Hence, with the increase in mass of one or both the objects, the force of attraction increases and with increasing distance between them, the force of attraction decreases.

## 5.2. Universal gravitational constant (G)

The universal gravitational constant can be understood and defined from the mathematical expression of gravitational force (equation 1).

$$\text{If } m_1 = m_2 = 1 \text{ unit and } r = 1 \text{ unit, then } |F| = G$$

(1 unit mass = 1 kilogram or 1 gram or 1 pound; 1 unit distance = 1 meter or 1 centimetre or 1 feet depending on the system of unit)

**Definition:**

**The universal gravitational constant can be defined as the Gravitational force of attraction between two unit masses placed unit distance apart in the universe.**

**Unit:**

From equation 1,

$$G = \frac{F \times r^2}{m_1 m_2}$$

$$\text{Hence, unit of G is } \frac{\text{Newton} \times \text{meter}^2}{\text{kilogram}^2} = \text{Nm kg}^{-2}$$

Now, Newton = Kg m s<sup>-2</sup>

So, unit of G in SI unit is m<sup>3</sup>kg<sup>-1</sup>s<sup>-2</sup>

**Dimension:**

$$[G] = \frac{[F][r]^2}{[m_1][m_2]} = \frac{[MLT^{-2}] \times [L^2]}{[M^2]} = [M^{-1}L^3T^{-2}]$$

## 5.3. Acceleration due to gravity (g):

### 5.3.1 : Gravitational force of earth

The Earth by virtue of its mass, attracts each body towards its *centre*. This is the reason an object thrown upward falls back in a straight line and a projectile projected with certain initial velocity also falls back to earth after traversing a curved path.

Galileo Galilei after performing a series of experiment showed that all object falls with a constant acceleration if left to fall freely. The numerical value of  $g$  is approximately  $9.8 \text{ m/s}^2$  in SI,  $980 \text{ cm/s}^2$  in C.G.S or  $32 \text{ ft/s}^2$  in F.P.S system near the Earth's surface. The value changes with altitude and depth from the surface of earth.

#### **5.3.2. Unit and dimension:**

The unit of  $g$  is  $\text{m/s}^2$  in SI unit and the dimension is same as that of acceleration i.e.  $[M^0L^1T^{-2}]$ .

#### **5.4. Mass and weight:**

### Mass

- Mass of any object is the amount of matter that an object possesses.
- Mass is constant irrespective of place and time.
- Mass can never be zero
- The unit of mass is g, kg etc.
- Mass is a scalar quantity.

### Weight (W)

- Weight of an object is the measurement of the gravitational force acting on the object;  $W = mg$ .
- The value of weight depends on the value of „acceleration due to gravity“ at the place and is not constant.
- Weight can be zero where acceleration due to gravity becomes zero.
- The unit of weight is Newton and Dyne .
- Weight is a vector quantity. It is directed towards the centre of earth.

### 5.5 Relation between g and G:

Suppose the mass of the Earth = M, Mass of the object on the surface of the earth = m,  
Radius of earth= R.

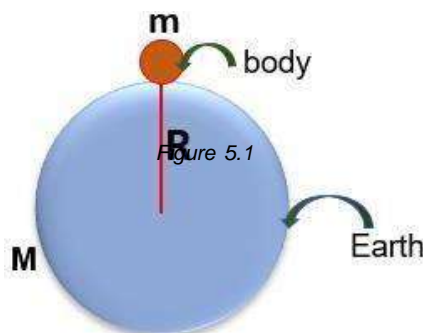

Figure 5.2

Then, the magnitude of the gravitational force acting on the mass m by Earth is

$$F = G \frac{Mm}{R^2} \dots\dots\dots (2)$$

If the acceleration of the object is g, then according to Newton's 2<sup>nd</sup> Law,

$$F = mg \dots\dots\dots (3)$$

By comparing equation 2 and 3,

$$g = \frac{GM}{R^2} \text{-----(4)}$$

Equation 4 describes the relationship between acceleration due to gravity (g) and universal gravitational constant (G).

**Example 1**

A mass of 2 kg experiences a weight of 18N on a planet. What is the value „g“ on the planet?

**Answer:**

$$\text{Weight} = mg = 18 \text{ N}, g = \frac{18}{m} = \frac{18}{2} = 9 \text{ ms}^{-2}$$

**Example 2**

Find the force of gravitational attraction between two neutrons whose centres are  $10^{-12}\text{m}$  apart. Given  $G = 6.67 \times 10^{-11} \text{ Nm}^2\text{kg}^{-2}$ , mass of neutron =  $1.67 \times 10^{-27} \text{ g}$

**Answer:**

Here,  $m_1 = m_2 = 1.67 \times 10^{-27} \text{ kg}, r = 10^{-12}\text{m}, G = 6.67 \times 10^{-11} \text{ Nm}^2\text{kg}^{-2}$

$$\text{So, } F = G \frac{m_1 m_2}{r^2} = 6.67 \times 10^{-11} \frac{(1.67 \times 10^{-27})^2}{10^{-24}} = 1.8 \times 10^{-40} \text{ N}$$

**Example 3**

Two bodies of masses 2 kg (body A) and 5 kg (body B) are placed separated by a distance of 0.4 m. Assuming the only forces acting between them are due to gravitational interaction, find their initial accelerations.

**Answer:**

The two bodies will experience gravitational force F which are equal in magnitude and opposite in direction

$$F = G \frac{m_1 m_2}{r^2} \Rightarrow F = 6.67 \times 10^{-11} \frac{2 \times 5}{0.4^2} = 41.7 \times 10^{-10} \text{ N}$$

If  $a_1$  and  $a_2$  are the initial accelerations of body A and B respectively,

$$a_1 = \frac{F}{m_1} = \frac{41.7 \times 10^{-10}}{2} = 20.85 \times 10^{-10} \text{ m/s}^2$$

$$a_2 = \frac{F}{m_2} = \frac{41.7 \times 10^{-10}}{5} = 8.34 \times 10^{-10} \text{ m/s}^2$$

**Example 4:**

A body weighs 90 kg wt on the surface of the earth. How much will it weigh on the surface of the mars if its radius is  $\frac{1}{2}$  and mass  $\frac{1}{9}$  of the earth.

**Answer:**

Given, Mass of Mars =  $M_m = \frac{1}{9}$  Mass of Earth =  $\frac{1}{9} M_e$

Radius of Mars =  $R_m = \frac{1}{2}$  Radius of Earth =  $\frac{1}{2} R_e$

Weight of body on the earth =  $W_e = mg_e = m \frac{GM_e}{R_e^2} = 90 \text{ kg wt}$

Weight on mars,  $W_m = mg_m = ?$

Where  $g_e$  and  $g_m$  are acceleration due to gravity on earth and mars, respectively.

$$g_m = \frac{GM_m}{R_m^2} = \frac{G \frac{M_e}{9}}{\frac{R_e^2}{4}} = \frac{4}{9} \times \frac{GM_e}{R_e^2} = \frac{4}{9} g_e$$

where  $M_e$  and  $M_m$  are the masses of earth and mars, respectively and  $R_e$  and  $R_m$  are the respective radii.

$$\text{So, } W_m = mg_m = \frac{4}{9} m g_e = \frac{4}{9} \times 90 = 40 \text{ kg wt.}$$

**5.6 Variation of g with altitude and depth****a: Variation with altitude**

Let us represent earth as shown in the below figure.

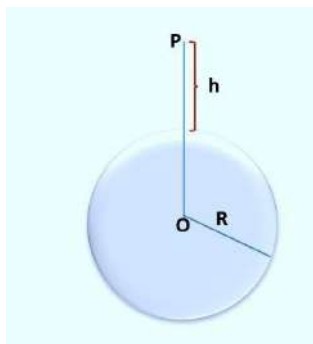

Figure 5.3

An object of mass  $m$  is placed at  $P$  at a height  $h$  from the Earth's surface.

Let us denote  $g$  = acceleration due to gravity at the Earth's surface.

$$\text{So, } g = \frac{GM}{R^2}$$

where, M = mass of earth

R = Radius of earth

Now, the value of acceleration due to gravity at a height h from the Earth's surface = g'

$$\text{So, } g' = \frac{GM}{(R+h)^2} = \frac{M}{R^2(1+\frac{h}{R})^2} = \frac{g}{(1+\frac{h}{R})^2} = (1 + \frac{h}{R})^{-2}$$

If  $h \ll R$ , then, only the first two terms of the binomial expansion of  $(1 + \frac{h}{R})^{-2}$  are considered and higher powers of h can be neglected.

$$\text{i.e. } (1 + \frac{h}{R})^{-2} \cong 1 - \frac{2h}{R}$$

$$\text{So, } g' \cong (1 - \frac{2h}{R}) \dots \dots \dots (5)$$

From equation 5, it is clear that **the acceleration due to gravity decreases with increasing height.**

**b: Variation with depth:**

Let us represent earth as follows. Let the surface of earth (the sphere) be called S.

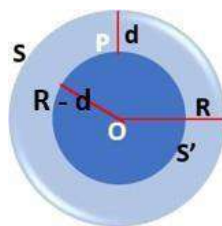

Figure 5.4

Let g = acceleration due to gravity on the surface of the earth

and g' = acceleration due to gravity at depth d below the surface of earth

$$\text{Now, } g = \frac{GM}{R^2}$$

$$\text{Here, } M = \frac{4}{3} \pi R^3 \rho,$$

where,  $\rho$  = mass density of earth,

$$\text{So, } g = \frac{G}{R^2} \times \frac{4}{3} \pi R^3 \rho = \frac{4}{3} \pi R \rho G \text{ -----(6)}$$

$$\text{Similarly, } g' = \frac{4}{3} \pi (R - d) \rho G \text{ -----(7)}$$

Dividing equation 7 by 6,

$$\frac{g'}{g} = \frac{R-d}{R}$$

$$\Rightarrow g' = g \left(1 - \frac{d}{R}\right)$$

Hence, **the value of acceleration due gravity decreases with increasing depth.**

So, the value of acceleration due to gravity is maximum at the surface of the earth.

At the centre of the earth, where  $d = R$ ,  $g'$  becomes zero. So, the weight of the body ( $mg$ ) becomes zero at the centre of the earth.

**Example 5:**

A body has a weight 81N on the surface of the earth. How much will it weigh when taken to height equal to half of the radius of earth?

**Answer:**

Let  $F_1$  be the weight (gravitational attraction on the body due to earth) of body on the earth surface.

$$F_1 = \frac{GMm}{R^2} \text{ -----(8)}$$

Here,  $M$ = mass of earth,  $m$  = mass of the body and  $R$ = radius of the earth

When, taken to a height  $R/2$  from the surface, the distance „ $x$ “ of the body from the centre of earth is  $x = R + \frac{R}{2} = \frac{3R}{2}$

$$\text{Weight } F_2 \text{ at this place is } F_2 = \frac{GMm}{x^2} = \frac{GMm}{\left(\frac{3R}{2}\right)^2} = \frac{4}{9} \frac{GMm}{R^2} \text{ -----(9)}$$

Dividing equation 9 by 8,

$$\frac{F_2}{F_1} = \frac{4}{9}$$

$$\text{As } F_1 = 81\text{N. } F_2 = \frac{4}{9} \times 81\text{N} = 36 \text{ N}$$

**Example 6:**

A mass of 5 kg is weighed on a balance at the top of a tower 20 m high. The mass is then suspended from the pan of the balance by a fine wire 20 m long and is reweighed. Find the change in the weight in milligram. (Given radius of earth = 6330 km).

**Answer:**

$$m = 5 \text{ kg, } h = 20 \text{ m} = 0.02 \text{ km}$$

$$R = 6330 \text{ km}$$

$$\text{Now, } \frac{g'}{g} = 1 - \frac{2h}{R} \Rightarrow g' = g - \frac{2hg}{R} \Rightarrow g - g' = \frac{2hg}{R}$$

$$\text{So, change in weight} = mg - mg' = \frac{2mhg}{R} = \frac{2 \times 5 \times 0.02 \times g}{6330} = 3.09 \times 10^{-4} \text{ N}$$

**5.7 Kepler's Law of Planetary Motion:**

Kepler's laws of planetary motion are the laws describing the motion of planets around the sun.

**1<sup>st</sup> law (Law of Elliptical orbit):**

All the planets revolve in elliptical orbits with the Sun situated at one of its foci. The point at which the planet is close to the sun is known as perihelion and the point at which the planet is farther from the sun is known as aphelion.

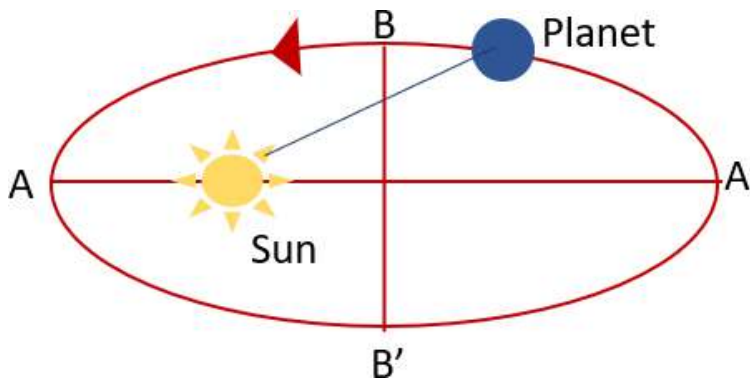

Figure 5.5.

In the figure, AA' is the major axis of the ellipse with length 2R and BB' is the minor axis with length 2b.

Since the focus of an ellipse is not equidistant from the point of orbit, the distance of planet varies from certain minimum to maximum value. Here, the rotation is the reason

of season change from summer (nearer the sun) to winter (farther from the sun) and repetition of same year after year.

The first law explains the change of season.

### 2<sup>nd</sup> law (Law of areal velocity)

The areal velocity of the planet is constant. That means, the line joining the sun to the planet sweeps equal area in equal interval of time.

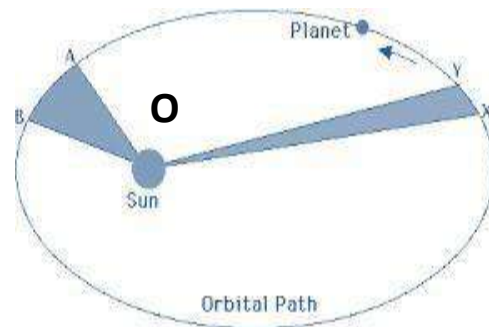

Figure 5.6

According to the law :

If the planet moves from X to Y in time  $t$  and from A to B in the same time interval  $t$  later, then the area OAB = area OXY.

$$\Rightarrow AB \times OA = XY \times OX$$

From the figure it is clear that :  $OA < OX$

Therefore ;  $AB > XY$

Since the areal velocity is constant, the time taken by planet to move from A to B = the time taken by planet to move from X to Y.

Since  $AB > XY$  , the planet moves faster when travels from A to B and moves slower when travels from X to Y. Thus the orbital velocity of planet is not uniform. It is maximum when the planet is nearest to sun ( summer season ) and minimum when the planet is away from the sun at a maximum distance ( winter season ).

### 3<sup>rd</sup> law (Law of time period)

The square of the time period of a planet is proportional to the cube of the semi major axis of the ellipse.

$$T^2 \propto R^3$$

Where  $T$  = time period of the orbiting planet and  $R$  = semi-major axis of the elliptic orbital

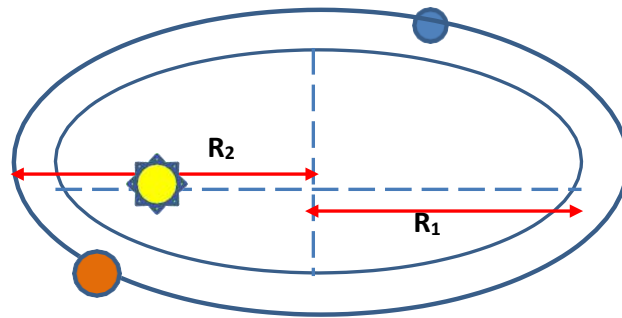

Figure 5.7

If two planets revolve around sun in two separate orbits with respective semi major axes as  $R_1$  and  $R_2$ , then the time period of the planets are related to  $R_1$  and  $R_2$  as

$$\frac{T_1^2}{T_2^2} = \frac{R_1^3}{R_2^3}$$

# EXERCISE

## VERY SHORT ANSWER QUESTIONS (2 marks)

1. State the unit of  $g$  and calculate its dimension.
2. How does  $g$  vary with altitude and depth?
3. State the unit of  $G$  and calculate its dimension.

## SHORT ANSWER QUESTIONS (5 marks)

1. State and explain Newton's laws of gravitation. Define  $G$ .
2. Differentiate between mass and weight.
3. State and explain the three laws of planetary motion.
4. Derive the relation between  $g$  and  $G$ .

## LONG ANSWER QUESTIONS (10 marks)

1. i. State and explain Newton's laws of gravitation  
ii. Two particles of masses 1 kg and 2 kg are placed at a distance of 25 cm. Assuming that the only forces acting on the particles are their mutual gravitational, find the initial acceleration of the two particles. Given  $G = 6.674 \times 10^{-11} m^3 kg^{-1} s^{-2}$

## UNIT 6

### OSCILLATIONS AND WAVES

#### 6.1 SIMPLE HARMONIC MOTION (SHM)

Let us understand oscillation and simple harmonic motion by taking real-life examples. In *Raja* festival, we swing. We sit comfortably at rest, then go up in one direction to an extreme point and then in the opposite direction to another extreme point. You might also have seen simple pendulum especially in old types of wall clock (see below figure) which moves to and fro about the centre. The swing and the pendulum are said to execute oscillation.

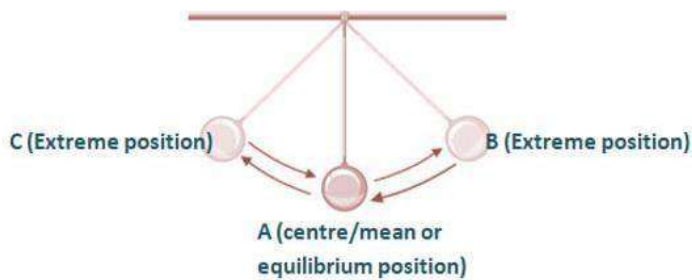

Figure 6.1a



Figure 6.1b

#### Definition:-

Simple Harmonic Motion (SHM) is defined as the type of periodic motion in which the restoring force is proportional to the displacement from its mean position of rest and always directed towards the mean position.

Let, a particle is displaced by a distance  $y$  from its mean position and „F“ is the restoring force tends to bring the body to its mean position due to elasticity.

For a small displacement, the force is proportional to the displacement and opposes the increase of displacement.

Hence,  $F \propto -y$ ,

Restoring force  $F = \text{mass} \times \text{acceleration}$

$\Rightarrow ma = -Ky$ ,

$K = \text{Proportionality constant called force constant}$

$\Rightarrow a = -(K/m)y \Rightarrow a \propto -y$ ,

The negative sign shows that acceleration is always directed towards the mean position as it opposes the increase in displacement.

Thus in Simple Harmonic Motion acceleration ( $a$ ) is directly proportional to the displacement ( $y$ ) and is always directed towards the mean position

Example:

- i. Motion of simple pendulum
- ii. Motion of a spring-block system
- iii. Vibration of stretched string
- iv. Bungee-jumping
- v. Swing
- vi. Cradle etc.

## 6.2 EXPRESSION FOR DISPLACEMENT, VELOCITY, ACCELERATION OF A PARTICLE EXECUTING SHM

Let us consider a particle moving in a uniform circular motion with a constant angular velocity  $\omega$ .

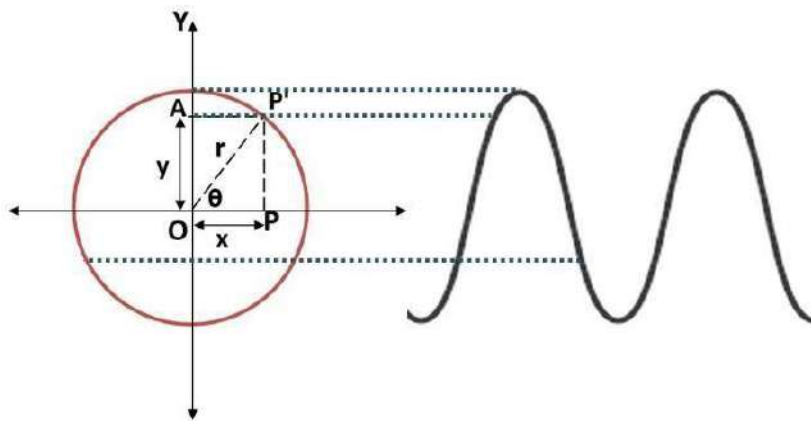

The projection of the motion of particle makes a simple harmonic motion along the diameter of the circle of reference. *Figure 6.2*

The projection of the particle at time  $t = 0$  is O.

At an instant of time  $t$ , the projection of the particle at P' is A.

Then,  $OA = y =$  displacement of the particle at time  $t$

$OP' =$  radius of the reference circle  $= r$

Then,  $\theta =$  angular displacement & *Angular velocity*  $= \omega = \frac{\theta}{t} \Rightarrow \theta = \omega t$

**a. Equation of Displacement:**

In the right angled triangle  $OPP'$ ,  $\sin\theta = \frac{PP'}{OP'} = \frac{y}{r}$

$$\Rightarrow y = r \sin\theta = r \sin \omega t$$

Where,  $r =$  amplitude of SHM

$y =$  displacement of particle from the mean position at an instant of time  $t$ .

**b. Equation of Velocity:**

$$v = \frac{dy}{dt} = \frac{d}{dt}(r \sin \omega t) = r \frac{d}{dt}(\sin \omega t) = r \omega \cos \omega t$$

$$\Rightarrow v = r \omega \cos \omega t = r \omega \sqrt{1 - \sin^2 \omega t} = \omega \sqrt{r^2 - y^2}$$

So, at mean position,  $y = 0$ , So,  $v = \omega \sqrt{r^2 - 0^2} = r\omega$  which is maximum.

At extreme positions,  $y = \pm r$ , So,  $v = \omega \sqrt{r^2 - r^2} = 0$  which is minimum.

Hence, a particle executing SHM has zero velocity at the extreme positions and maximum velocity at the mean position.

**c. Equation of Acceleration:**

$$a = \frac{dv}{dt} = \frac{d}{dt}(r \omega \cos \omega t) = r \omega \frac{d}{dt}(\cos \omega t) = -r \omega^2 \sin \omega t$$

$$\Rightarrow a = -\omega^2 (r \sin \omega t) = -\omega^2 y$$

Hence,  $a \propto -y$  (proved)

$$\text{Now, } |a| = \omega^2 y$$

At the mean position,  $y = 0$ ,  $a = 0$ ; minimum

At extreme positions,  $y = \pm r$ ,  $|a| = \omega^2 r$ ; maximum

Hence, a particle executing SHM has zero acceleration at the mean position and maximum acceleration at the extreme positions.

**Example 1:**

If a particle executes simple harmonic motion of period 8 s and amplitude 0.40 m, find the maximum velocity and acceleration.

**Answer:**

Here,  $T = 8$  s.

$$\text{So, } \omega = \frac{2\pi}{T} = \frac{2\pi}{8} = \frac{\pi}{4} \text{ rad s}^{-1}$$

$$r = 0.40 \text{ m}$$

$$\text{Maximum velocity} = r\omega = 0.40 \times \frac{\pi}{4} = 0.3142 \text{ ms}^{-1}$$

$$\text{Maximum acceleration} = \omega^2 r = \left(\frac{\pi}{4}\right)^2 \times 0.40 = 0.2467 \text{ ms}^{-2}$$

**6.3 WAVE MOTION**

In the previous subsection we studied about the oscillation of single particle. Now let us study a situation where there is a collection of particles and the motion of one particle affects other. The simplest and relatable example is when we throw a stone into a pond which creates a disturbance in the still water. What we see is the disturbance is propagating outward in circles as shown in the below figure.



Figure 6.3

Now, the question is what is propagating? Is it the water particles which are moving themselves? This can be tested by putting a small paper on the water. We can see that the paper will execute an „up and down“ motion. Hence, it can be inferred that the water particles are moving up and down where the disturbance is propagated outwards.

When there is a disturbance in a medium, due to elasticity of the particle of the medium, the particles execute to and fro motion about their mean position, as a result the energy as well as momentum transfer from one particle to another and so on. In this way wave is produced.

When the wave propagates, the particles of the medium are not moving along with the wave, but they are vibrating about the mean position.

## 6.4 TRANSVERSE AND LONGITUDINAL WAVE MOTION

### Transverse wave:

- The type of wave in which the particle of the medium vibrate perpendicular to the direction of propagation is called transverse wave.
- It results in the formation of crest and trough

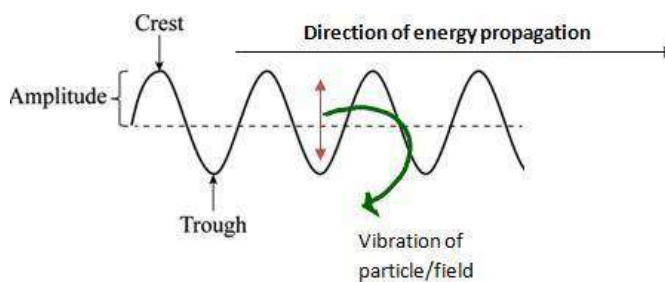

Figure 6.4

- The distance between two consecutive crests or troughs is called as wavelength ( $\lambda$ ).
- Density of medium does not vary.
- Electromagnetic wave is a kind of transverse wave for which medium may or may not be required.
- Example, all electromagnetic waves (light wave, radio wave, microwave etc.), wave in a string

### Longitudinal wave:

- The type of wave in which the particles of the medium vibrate parallel to the direction of propagation is called longitudinal wave.
- It results in the formation of compression and rarefaction (figure 6.5).
- The distance between two consecutive centres of compressions or rarefactions is called wavelength ( $\lambda$ ).
- Density of medium is higher at compression and lowest at rarefaction.
- Longitudinal wave needs medium for its propagation.
- Example, Sound wave

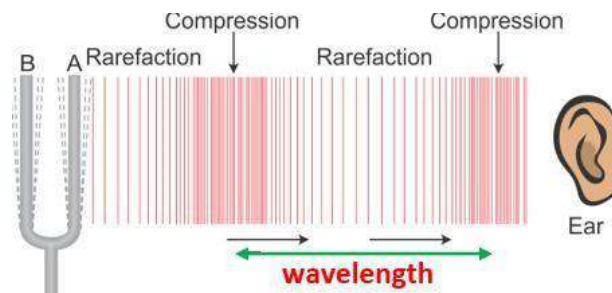

Figure 6.5

### Transverse Wave

- 1 In a transverse wave motion, the particles of the medium/field vibrate in a direction perpendicular to the direction of propagation of the wave. For example, electromagnetic wave.
- 2 The region of maximum upward displacement is called the crest and the maximum downward displacement is called trough.
- 3 Electromagnetic wave is a kind of transverse wave which may travel without a material medium.
- 4 Density of the medium does not vary

### Longitudinal Wave

- 1 In a longitudinal wave motion, the particles of the medium vibrate in a direction parallel to the direction of propagation of the wave. For example, sound wave.
- 2 Longitudinal wave is propagated via compression and rarefaction.
- 3 Longitudinal wave needs a medium for its propagation.
- 4 Density of the medium is higher at compression and lower at rarefaction.

## 6.5 DEFINITION OF DIFFERENT WAVE PARAMETERS

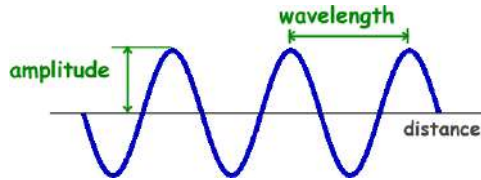

Figure 6.6

### **Amplitude:**

The amplitude of a wave is a measure of the maximum displacement of the wave from its equilibrium position in either side. (Figure 6.6).

The amplitude is a measure of the intensity of the wave. To be particular, intensity is the square of amplitude.

SI Unit -----Metre

Dimension----- (L)

### **Wavelength ( $\lambda$ ):**

It is the linear distance covered during one full wave or one full cycle.

SI Unit----Metre

Dimension----- (L)

The distance over which the shape of a wave repeats is called its wavelength. It is the distance between successive points of the same phase on the wave, such as two adjacent crests, troughs, or zero crossings (figure 6.6).

### **Time Period (T):**

Time taken by a particle of the medium to describe or complete one full wave is called Time- period.

SI Unit -----Second

Dimension ----- (T)

### **Frequency (f):**

It is the number of complete waves/full cycles described by the particle in 1 second.

$$\text{Frequency} = \frac{1}{\text{time period}} = \frac{1}{T}$$

SI Unit -----Cycles/Second =  $\text{sec}^{-1}$  = HERTZ (Hz)

Dimension ----- (T<sup>-1</sup>)

**Wave Velocity (v):**

The linear distance covered or travelled by a wave per unit time (in 1 sec)

SI Unit-----Metre /second

Dimension----- (L/T) or (LT<sup>-1</sup>)

**6.6 RELATION BETWEEN VELOCITY, FREQUENCY AND WAVELENGTH**

The wave velocity (v) is defined as the distance covered by a wave per unit time.

We know, the distance covered in a time period T is the wavelength  $\lambda$

So, the distance covered in unit time is  $\frac{\lambda}{T}$

That means  $v = \frac{\lambda}{T}$

But,  $f = \frac{1}{T}$

$$\Rightarrow v = f\lambda \text{ -----(6)}$$

Equation 6 depicts the relationship between velocity, frequency and wavelength.

**Example 2:**

A broadcasting station radiates at a frequency 710 kHz. What is the wavelength in meter?

Given the wave velocity of waves =  $3 \times 10^8 \text{ m/s}$

**Answer:**

$$f = 710 \text{ kHz} = 710 \times 10^3 \text{ s}^{-1}$$

$$v = 3 \times 10^8 \text{ m/s}$$

$$\lambda = \frac{v}{f} = \frac{3 \times 10^8}{710 \times 10^3} = 422.5 \text{ m}$$

**6.7 ULTRASONICS**

The branch of Physics which deals with study of ultrasonic waves is called **Ultrasonic**.

The sound wave having frequency above 20 kHz or 20,000 Hz are known as **Ultrasonic waves**.

The sound audible to human ear lies in the frequency range of 20 Hz to 20 kHz. The sound wave with higher frequency i.e., in the range of 20 kHz to several GHz is called ultrasonic waves.

**Properties:**

- Ultrasonic waves possess high frequency and hence high energy.
- Accordingly, the wavelength of ultrasonic waves is small.

- As ultrasonic waves are sound waves, they require material medium for their propagation.
- With high energy, ultrasonic waves produce heating effect in the medium through which they pass.
- Ultrasonic wave can accelerate chemical reactions and hence can facilitate material synthesis.

**Applications:**

- In sonar system, ultrasonic waves are used to estimate the depth of ocean.
- Ultrasonic is used to locate divers, fish and to detect sunk ships and other under water bodies. This is done by sending high intense ultrasonic pulses and by detecting the reflected wave.
- Ultrasonic is used in scanning to detect any anomaly in the internal organs.
- Ultrasonic waves can be used for localized destruction of unwanted body cells or bacteria.
- Ultrasonic drills are used for shaping, cutting and machining of materials.
- Ultrasonic baths are heavily used in industries and laboratories for cleaning remote parts of machineries.
- Fine particles of dust, smoke and ash coagulate when they are subjected to ultrasonic waves. This method is employed by industries to remove smoke from industrial stack, acid fumes etc.

# EXERCISE

## Very short type questions (2 marks each)

1. Define simple harmonic motion
2. Define wave motion.
3. Define amplitude and wavelength of a wave.
4. Define frequency and time period of a wave. State the relationship between them.
5. Derive the relationship between velocity, frequency and wavelength of a wave.
6. Define ultrasonics.

## Short type questions (5 marks each)

1. Compare transverse and longitudinal wave.
2. Write the properties of ultrasonic wave.
3. Write five applications of ultrasonic wave.

## Long type questions (10 marks each)

1. Define simple harmonic motion (SHM). Derive the expressions for displacement, velocity and acceleration of a body executing SHM.
2. Define ultrasonic. State the properties and applications of ultrasonic waves.

## **UNIT- 7**

### **HEAT AND THERMODYNAMICS**

#### **7.1 Heat and Temperature:**

Out of different sensations of human beings, one is called sensation of warmth. If we stand in the sun or near a fire, we feel hot. It means something from sun or fire enters our body and excites the sensation of warmth.

A glass of ice-cold water left on a table on a hot summer day eventually warms up whereas a cup of hot tea on the same table cools down. It means that when the temperature of body and its surrounding medium are different, heat transfer takes place between the system and the surrounding until the body and surrounding medium attains the same temperature. We also know that in the case of glass tumbler of ice-cold water, heat flows from environment to the glass tumbler, whereas in case of hot tea, it flows from the cup of hot tea to the environment.

In this chapter we will discuss some parameters involving heat phenomena, change of state, processes where heat is converted into work and effect of heat on the expansion of substance.

#### **Heat**

Heat is defined as the form of energy transferred between two (or more) systems or between a system and its surroundings by virtue of temperature difference. Heat is the agent that produces the sensation of warmth.

#### **Temperature**

Temperature is defined as the degree of hotness or coldness of a body. Temperature is a relative measure or indication of hotness or coldness of a body. A hot utensil is said to have a high temperature and ice cube is said to

have a low temperature. An object that has a high temperature as compared to another object is said to be hotter. We can perceive temperature by touch.

Temperature is also defined as the thermal state or condition of a body which determines the direction of heat flow when bodies are placed in contact.

### **Difference between Heat and Temperature**

<b>Heat</b>	<b>Temperature</b>
<b>Heat is the energy in transit which transfers from one body to other because of temperature difference between them.</b>	Temperature is the degree of hotness or coolness of a body.
<b>Heat is the total energy of the constituent molecules of an object.</b>	Temperature is the measure of average kinetic energy of the molecules in a substance.
<b>Heat flows from hot body to cold body.</b>	Temperature rises when an object is heated and falls when it is cooled down.
<b>Its unit is Joule in S.I, Calorie in C.G.S. and British Thermal Unit (B.T.U.) in F.P.S.</b>	<b>Its unit is Kelvin in S.I, degree Celsius in C.G.S. and degree Fahrenheit in F.P.S.</b>
<b>It is a derived physical quantity.</b>	<b>It is a fundamental physical quantity.</b>
<b>Heat is exchangeable, it flows from one body to another.</b>	<b>Temperature is not exchangeable.</b>
<b>Heat transfer is a reason behind temperature change.</b>	<b>Temperature variation is the result of gain or loss of heat.</b>
<b>The dimensional formula of Heat is <math>[M^1L^2T^{-2}]</math>.</b>	<b>The dimensional formula of temperature is <math>[M^0L^0T^0K^1]</math>.</b>

## 7.2 Units of heat

Heat is measured in following units:

System of Units	Unit of heat
F.P. S	British Thermal Unit (B.T.U)
C.G. S	Calorie(Cal.)
M.K. S	Joule(J)
S. I	Joule(J)

## 7.3 Specific Heat

If " $\Delta Q$ " stands for amount of heat absorbed by a substance of mass " $m$ " when it undergoes a temperature change " $\Delta T$ ", then

$\Delta Q \propto m$  (the greater the mass, greater the amount of heat required)

$\Delta Q \propto \Delta T$  (more the amount of heat absorbed, higher the rise in temperature)

Combining the two factors together,

$$\Delta Q \propto m\Delta T$$

Or  $\Delta Q = Cm\Delta T$

Where " $C$ " is the specific heat of the substance and it is given by

$$C = \frac{\Delta Q}{m\Delta T}$$

If  $m = 1$  unit,  $\Delta T = 1$  unit,

$$\Rightarrow C = \Delta Q$$

Specific heat is defined as the amount of heat required to raise the temperature of a unit mass of substance through unit degree.



$$Q = mC\Delta T$$

$$Q = (0.100 \text{ kg}) \cdot (129 \text{ J kg}^{-1}\text{K}^{-1}) \cdot (50.0 \text{ K}) = 645 \text{ J}$$

So, the heat energy required to raise the temperature of 100 g gold is 645 J.

#### Example 2

A pot is heated by transferring 1676 KJ of heat energy to the water. If there is 5.00 kg of water in the pot and the temperature is raised by 80.0 K, then find the specific heat of water?

#### **Solution:**

It is given that,

$$\text{Mass (m)} = 5.00\text{kg}$$

$$\text{Temperature } (\Delta T) = 80.0 \text{ K}$$

$$\text{Heat supplied (Q)} = 1676 \text{ KJ} = 16,76,000 \text{ J}$$

$$\text{Specific heat, } C = \frac{Q}{m\Delta T}$$

Now putting values in the above formula, we get,

$$C = \frac{1676000}{(5.00)(80.0)} = 4190 \text{ J kg}^{-1}\text{K}^{-1}$$

Hence, the specific heat of water is 4190 J kg<sup>-1</sup> K<sup>-1</sup>.

### **7.4 Change of state**

We know that ice (solid) gets converted to water(liquid) while water gets converted into steam(gas) on heating. This is, in general, true for all materials. Different names assigned to various processes of conversion of matter from one state to other is shown in Fig 7.1.

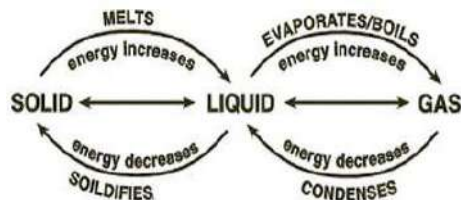

Fig. 7.1

On absorbing heat, molecules of matter become more energetic and start vibrating more vigorously. When their energy increases to such an extent that they become capable of leaving their mean positions, solid is converted into liquid. On further heating, molecules undergo translatory motion more vigorously, but they cannot leave the boundary of liquid. When their energy becomes high enough to cross the barrier of the surface of liquid, they go in space and become almost free. The substance is said to be converted into a gas.

On deriving heat from matter, molecules lose energy gradually, and the matter follows a reversed path, going from gas to liquid and then to solid.

**The transition from solid to liquid state is called ‘Melting’ and the transition from liquid to solid state is called ‘Freezing’.**

**The transition from liquid to gaseous state is called ‘Vaporization’ and the transition from liquid to solid state is called ‘Condensation’.**

**The direct transition from solid to gaseous state is called ‘sublimation’ and the transition from gaseous to solid state is called ‘deposition’.**

**Definition of latent heat: -**

During a phase transition, the supplied heat is solely used to change the state and do not raise the temperature of the material.

The amount of heat required to change the state of unit mass of substance at constant temperature.

Latent heat (L) is given by,

$$L = \frac{Q}{m}$$

Where, Q is the amount of heat supplied and m is the mass of the substance.

**Latent heat of fusion( $L_f$ )** of a substance is defined as the amount of heat required to convert a unit mass of substance from solid to liquid state at the melting point without any change in temperature. ( $L_f$  of ice = 80 cal. gm<sup>-1</sup>).

**Latent heat of vaporization( $L_v$ )** a substance is defined as the amount of heat required to convert a unit mass of liquid into its vapours at its boiling point without any change in temperature. ( $L_v$  of water = 540 cal. gm<sup>-1</sup>).

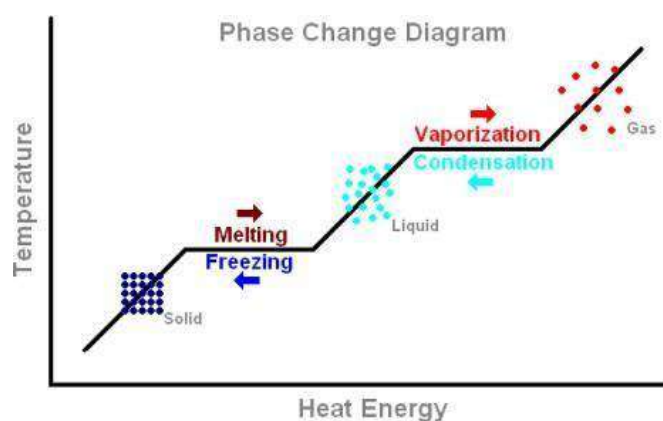

Fig. 7.2

### Units and Dimension of Latent Heat:

We know

$$L = \frac{Q}{m}$$

In C.G.S, the unit of heat(Q) is calorie and the unit of mass(m) is gram.Hence the unit of latent heat in C.G.S is **Cal g<sup>-1</sup>**.

In S.I the unit of heat(Q) is Joule and the unit of mass(m) is kilogram.Hence the unit of latent heat in S.I is **J kg<sup>-1</sup>** .

The dimensional formula of latent heat,

$$[L] = \frac{[M^1 L^2 T^{-2}]}{[M^1]} = [M^0 L^2 T^{-2}]$$

So, the dimensions of latent heat are 0,2,-2 with w.r.t mass, length and time respectively.

### Principle of Calorimetry:

When two or more substances at different temperature are mixed with each other they exchange heat with each other till the mixture attains a constant temperature. The process is governed by principle of calorimetry which can be stated as follows. The principle forms the bases of experimental determination of specific heat capacity or specific latent heat.

Whenever two or more substances, at different temperature are mixed with each other, the net amount of heat lost by some substances is equal to that gained by the others provided no heat is lost to the surroundings.

**Example 1:** Determine the latent heat of a 10kg substance if the amount of heat required for a phase change is 200kcal.

#### Solution:

Given that Mass (M) = 10 kg, Amount of heat (Q) = 200k.cal.

By using the formula,

$$\text{Latent heat} = Q/M = 200/10 = 20\text{kcal kg}^{-1}$$

#### Example 2

Calculate the heat required to convert 3 kg of ice at  $-12^\circ\text{C}$  to steam at  $100^\circ\text{C}$  at atmospheric pressure. Given specific heat capacity of ice=2100

$\text{Jkg}^{-1}\text{K}^{-1}$ , specific heat capacity of water =  $4186 \text{ Jkg}^{-1}\text{K}^{-1}$ , latent heat of fusion of ice =  $3.35 \times 10^5 \text{ Jkg}^{-1}$  and latent heat of steam =  $2.256 \times 10^6 \text{ Jkg}^{-1}$

### Answer

We have,

Mass of the ice,  $m = 3 \text{ kg}$

Specific heat capacity of ice,  $C_{\text{ice}} = 2100 \text{ J kg}^{-1} \text{ K}^{-1}$

Specific heat capacity of water,  $C_{\text{water}} = 4186 \text{ J kg}^{-1} \text{ K}^{-1}$

Latent heat of fusion of ice,  $L_{\text{ice}} = 3.35 \times 10^5 \text{ J kg}^{-1}$

latent heat of steam,  $L_{\text{steam}} = 2.256 \times 10^6 \text{ J kg}^{-1}$

Now,  $Q$  = heat required to convert 3 kg of ice at  $-12 \text{ }^\circ\text{C}$  to steam at  $100 \text{ }^\circ\text{C}$ ,

$Q_1$  = heat required to convert ice at  $-12 \text{ }^\circ\text{C}$  to ice at  $0 \text{ }^\circ\text{C}$ .

$$= m C_{\text{ice}} \Delta T = (3 \text{ kg}) (2100 \text{ J kg}^{-1} \text{ K}^{-1}) [0 - (-12)] \text{ }^\circ\text{C} = 75600 \text{ J}$$

$Q_2$  = heat required to melt ice at  $0 \text{ }^\circ\text{C}$  to water at  $0 \text{ }^\circ\text{C}$

$$= m L_{\text{ice}} = (3 \text{ kg}) (3.35 \times 10^5 \text{ J kg}^{-1}) = 1005000 \text{ J}$$

$Q_3$  = heat required to convert water at  $0 \text{ }^\circ\text{C}$  to water at  $100 \text{ }^\circ\text{C}$ .

$$= m C_{\text{water}} \Delta T = (3 \text{ kg}) (4186 \text{ J kg}^{-1} \text{ K}^{-1}) (100 \text{ }^\circ\text{C}) = 1255800 \text{ J}$$

$Q_4$  = heat required to convert water at  $100 \text{ }^\circ\text{C}$  to steam at  $100 \text{ }^\circ\text{C}$ .

$$= m L_{\text{steam}} = (3 \text{ kg}) (2.256 \times 10^6 \text{ J kg}^{-1}) = 6768000 \text{ J}$$

So, the total amount of heat required is,

$$Q = Q_1 + Q_2 + Q_3 + Q_4$$

$$= 75600 \text{ J} + 1005000 \text{ J} + 1255800 \text{ J} + 6768000 \text{ J}$$

$$= 9.1 \times 10^6 \text{ J}$$

### 7.5 Thermal expansion:

It is our common experience that most substances expand on heating and contract on cooling. A change in the temperature of a body causes change in its dimensions.

The increase in the dimensions of a body due to the increase in its temperature is called thermal expansion.

### 7.6 Thermal Expansion of Solids: -

Thermal expansion is very evident in solids as atoms are densely packed. The three types of thermal expansions in solids are Linear expansion, Superficial expansion and Cubical expansion.

### 7.7 Coefficient of Linear Expansion ( $\alpha$ ): -

The expansion in one dimension or increase in length, breadth or height is called as linear expansion.

Consider a rod of certain material having length  $L_0$  at  $0^\circ\text{C}$ . Let the length become  $L_t$  at  $t^\circ\text{C}$ .

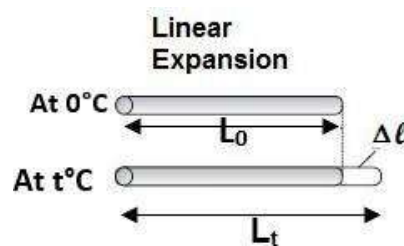

Fig. 7.3

Then, linear expansion =  $L_t - L_0$

This linear expansion depends upon the following factors:

- (i) Original length ( $L_0$ ), and varies directly with it,  
i. e.,  $(L_t - L_0) \propto L_0$ .
- (ii) Rise in temperature ( $t$ ), and varies directly with it,  
i.e.,  $(L_t - L_0) \propto t$ .

Combining above two relations, we get

$$(L_t - L_0) \propto L_0 t$$

Or  $(L_t - L_0) = \alpha L_0 t$

$$\Rightarrow L_t = L_0 + \alpha L_0 t = L_0 (1 + \alpha t) \dots \dots \dots (1)$$

$$\Rightarrow \alpha = \frac{L_t - L_0}{L_0 t} \dots \dots \dots (2)$$

where ' $\alpha$ ' is the constant of proportionality whose value depends upon the material of the rod. It is called coefficient of linear expansion of the material of the rod.

**Definition: Coefficient of linear expansion( $\alpha$ ) of the material is defined as the increase in length per unit original length per unit degree rise in temperature.**

Its unit in S.I is  $K^{-1}$  and in C.G.S  $^{\circ}C^{-1}$ .

**Coefficient of Superficial expansion ( $\alpha_s$ ):-**

**The expansion in two dimensions or increase in area of a body i.e increase in length and breadth due to heating is called as areal or superficial expansion.**

Consider a sheet of certain material with area  $A_0$  at  $0^{\circ}C$ .

Let the area become  $A_t$  at  $t^{\circ}C$ .

Then the superficial expansion ( $A_t - A_0$ ) depends upon original area ( $A_0$ ) and change in temperature ( $t$ ).

i.e.  $(A_t - A_0) \propto A_0$

$\propto t$

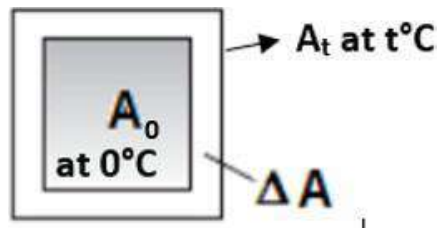

Fig. 7.4

Combining above two relations, we get

$$(A_t - A_0) \propto A_0 t$$

$$\text{Or } (A_t - A_0) = \beta A_0 t$$

$$\text{or } A_t = A_0 + \beta A_0 t = A_0(1 + \beta t) \dots \dots \dots (3)$$

$$\beta = \frac{(A_t - A_0)}{A_0 t} \dots \dots \dots (4)$$

where  $\beta$  is constant of proportionality whose value depends upon the material of the sheet. It is called coefficient of superficial expansion of the material of the sheet.

**Definition:** Coefficient of superficial expansion ( $\beta$ ) of the material is defined as the increase in area per unit original area per unit degree rise in temperature.

Its unit in S.I is  $\text{K}^{-1}$  and in C.G.S  $^\circ\text{C}^{-1}$ .

**Coefficient of cubical expansion ( $\gamma$ ):**

The expansion in three dimensions i.e in volume is called as volume expansion or cubical expansion.

Consider a body of certain material having volume  $V_0$  at  $0^\circ\text{C}$ . Let the volume become  $V_t$  at  $t^\circ\text{C}$ .

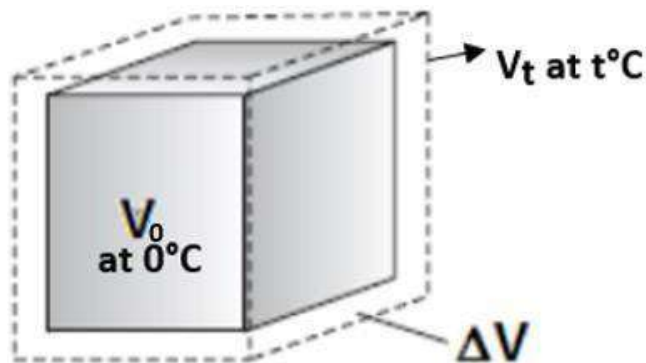

Fig. 7.5

Then, the cubical expansion ( $V_t - V_0$ ) depends upon original volume ( $V_0$ ) and change in temperature ( $t$ ).

$$V_t - V_0 \propto V_0$$

and

Combining above two relations, we get

$$V_t - V_0 \propto V_0 t$$

or

$$V_t - V_0 = \gamma V_0 t$$

$$\text{or } V_t = V_0 + \gamma V_0 t = V_0(1 + \gamma t) \dots \dots \dots (5)$$

$$\text{or } \gamma = \frac{(V_t - V_0)}{V_0 t} \dots \dots \dots (6)$$

where  $\gamma$  is the constant of proportionality whose value depends upon the material of the body. It is called coefficient of cubical expansion of the material of the body.

**Definition: Coefficient of cubical expansion ( $\gamma$ ) of the material is defined as the increase in volume of the cube per unit original volume per unit degree rise in temperature.**

Its unit in S.I is  $K^{-1}$  and in C.G.S  $^{\circ}C^{-1}$ .

**7.8 Relation between  $\alpha$ ,  $\gamma$  and  $\gamma$ :**

Take a cube of with length of its sides as  $L_0$  at  $0^{\circ}C$ , then the area of one of its faces  $A_0$  at  $0^{\circ}C = L_0^2$ .

Area at  $t^{\circ}C$  is  $A_t = L_t^2$

We know that length at  $t^{\circ}C$  is  $L_t = L_0(1 + \alpha t)$

By using this we get,

$$A_t = [L_0 (1 + \alpha t)]^2$$
$$\Rightarrow A_t = L_0^2 (1 + 2 \alpha t + \alpha^2 t^2)$$

As the value of  $\alpha$  is very small,  $\alpha^2$  term can be neglected.

$$\text{Then } A_t = L_0^2 (1 + 2 \alpha t)$$

$$\text{Hence, } A_t = A_0 (1 + 2 \alpha t) \text{ (as } L_0^2 = A_0) \dots\dots\dots (1)$$

$$\text{Since we know } A_t = A_0 (1 + \beta t) \dots\dots\dots (2)$$

From (1) and (2) above, we get

$$\beta = 2 \alpha \dots\dots\dots (3)$$

Thus, the coefficient of superficial expansion is twice the coefficient of linear expansion.

Similarly,

$$\text{Volume at } 0^\circ\text{C is } V_0 = L_0^3$$

$$\text{Volume at } t^\circ\text{C is } V_t = L_t^3$$

$$\text{We know that length at } t^\circ\text{Celsius is } L_t = L_0 (1 + \alpha t)$$

By using this we get,

$$V_t = [L_0 (1 + \alpha t)]^3$$
$$\Rightarrow V_t = L_0^3 (1 + 3 \alpha t + 3 \alpha^2 t^2 + \alpha^3 t^3)$$

As  $\alpha$  is small the higher orders of  $\alpha$  i.e.,  $\alpha^2$  and  $\alpha^3$  can be neglected.

$$\text{Then } V_t = L_0^3 (1 + 3 \alpha t)$$

$$\text{Hence } V_t = V_0 (1 + 3 \alpha t) \text{ (as } L_0^3 = V_0) \dots\dots\dots (4)$$

$$\text{Since we know } V_t = V_0 (1 + \gamma t) \dots\dots\dots (5)$$

On comparing (4) and (5) above, we get

$$\gamma = 3 \alpha \dots\dots (6)$$

Thus, the coefficient of cubical expansion is thrice of coefficient of linear expansion.

From (3) and (6) we get

$$\beta = 2 \alpha \Rightarrow \alpha = \beta / 2 \dots\dots\dots (7)$$

$$\gamma = 3 \alpha \Rightarrow \alpha = \gamma / 3 \dots\dots\dots (8)$$

From relation (7) and (8), we get

$$\therefore \gamma = 1:2:3$$

This is the required relation between  $\alpha$ ,  $\beta$ ,  $\gamma$ .

### Example 1

A steel is 40 cm long at 20 °C. The coefficient of linear expansion for steel is  $12 \times 10^{-6} \text{ } ^\circ\text{C}^{-1}$ . Find out the increase in length and the final length when it is at 70 °C.

Solution:

The change in temperature ( $\Delta T$ ) = 70°C - 20°C = 50°C

The original length ( $L_0$ ) = 40 cm

Coefficient of linear expansion for steel ( $\alpha$ ) =  $12 \times 10^{-6} \text{ } ^\circ\text{C}^{-1}$

The change in length, ( $L_t - L_0$ ) =  $\Delta L = \alpha L_0 \Delta T$

$$\Delta L = (12 \times 10^{-6} \text{ } ^\circ\text{C}^{-1})(40 \text{ cm})(50^\circ\text{C})$$

$$\Rightarrow \Delta L = (10^{-6}) (24 \times 10^3) \text{ cm}$$

$$\Rightarrow \Delta L = 24 \times 10^{-3} \text{ cm}$$

$$\Rightarrow \Delta L = 0.024 \text{ cm}$$

Now the final length,

$$L_t = L_0 + \Delta L$$

$$L_t = 40 \text{ cm} + 0.024 \text{ cm}$$

$$L_t = 40.024 \text{ cm}$$

### Example 2

An iron rod heated from 30 °C to 80 °C. The final length of iron is 115 cm and the coefficient of linear expansion is  $3 \times 10^{-3} \text{ } ^\circ\text{C}^{-1}$ . What is the original length and the change in length of the iron ?

Solution :

The change in temperature ( $\Delta T$ ) = 80 °C - 30 °C = 50 °C

The final length ( $L_t$ ) = 115 cm

The coefficient of linear expansion ( $\alpha$ ) =  $3 \times 10^{-3} \text{ } ^\circ\text{C}^{-1}$

Formula of the change in length for the linear expansion:

$$(L_t - L_0) = \Delta L = \alpha L_0 \Delta T$$

Formula of the final length :

$$L_t = L_0 (1 + \alpha \Delta T)$$

$$\Rightarrow 115 \text{ cm} = L_0 [1 + (3 \times 10^{-3} \text{C}^{-1}) (50^\circ \text{C})]$$

$$\Rightarrow 115 \text{ cm} = L_0 (1 + 150 \times 10^{-3})$$

$$\Rightarrow 115 \text{ cm} = L_0 (1 + 0.15)$$

$$\Rightarrow 115 \text{ cm} = L_0 (1.15)$$

$$\Rightarrow L_0 = 115 \text{ cm} / 1.15$$

$$\Rightarrow L_0 = 100 \text{ cm}$$

b) the change in length ( $\Delta L$ )

$$\Delta L = (L_t - L_0)$$

$$\Delta L = 115 \text{ cm} - 100 \text{ cm}$$

$$\Delta L = 15 \text{ cm}$$

Example 3:

At  $20^\circ \text{C}$ , the length of a sheet of steel is 50 cm and the width is 30 cm. If the coefficient of linear expansion for steel is  $10^{-5} \text{ }^\circ \text{C}^{-1}$ , determine the change in area and the final area at  $60^\circ \text{C}$  known:

The initial temperature ( $T_1$ ) =  $20^\circ \text{C}$

The final temperature ( $T_2$ ) =  $60^\circ \text{C}$

The change in temperature ( $\Delta T$ ) =  $60^\circ \text{C} - 20^\circ \text{C} = 40^\circ \text{C}$

The initial area ( $A_1$ ) = length x width = 50 cm x 30 cm = 1500  $\text{cm}^2$

The coefficient of linear expansion for steel ( $\alpha$ ) =  $10^{-5} \text{ }^\circ \text{C}^{-1}$

The coefficient of areal or superficial expansion for steel ( $\beta$ ) =  $2\alpha = 2 \times 10^{-5} \text{ }^\circ \text{C}^{-1}$

The change in area ( $\Delta A$ ) :

$$\begin{aligned} \Delta A &= \beta A_1 \Delta T = (2 \times 10^{-5} \text{ }^\circ \text{C}^{-1})(1500 \text{ cm}^2)(40^\circ \text{C}) \\ &= (80 \times 10^{-5})(1500 \text{ cm}^2) = 120,000 \times 10^{-5} \text{ cm}^2 \\ &= 1.2 \times 10^5 \times 10^{-5} \text{ cm}^2 \end{aligned}$$

$$\Delta A = 1.2 \text{ cm}^2$$

The final area ( $A_2$ ) =  $A_1 + \Delta A = 1500 \text{ cm}^2 + 1.2 \text{ cm}^2 = 1501.2 \text{ cm}^2$

Example 4:

At  $30^\circ \text{C}$  the volume of an aluminium sphere is 30  $\text{cm}^3$ . The coefficient of linear expansion is  $24 \times 10^{-6} \text{ }^\circ \text{C}^{-1}$ . If the final volume is 30.5  $\text{cm}^3$ , what is the final temperature of the aluminium sphere?

Solution:

The coefficient of linear expansion ( $\alpha$ ) =  $24 \times 10^{-6} \text{ }^\circ \text{C}^{-1}$

The coefficient of volume expansion, =  $3 \alpha = 3 \times 24 \times 10^{-6} \text{ }^\circ \text{C}^{-1} = 72 \times 10^{-6} \text{ }^\circ \text{C}^{-1}$

The initial temperature ( $T_1$ ) = 30°C

The initial volume ( $V_1$ ) = 30 cm<sup>3</sup>

The final volume ( $V_2$ ) = 30.5 cm<sup>3</sup>

The change in volume ( $\Delta V$ ) = 30.5 cm<sup>3</sup> - 30 cm<sup>3</sup> = 0.5 cm<sup>3</sup>

$$\Delta V = \gamma (V_1)(\Delta T)$$

$$\Delta V = \gamma (V_1)(T_2 - T_1)$$

$$0.5 \text{ cm}^3 = (72 \times 10^{-6}\text{C}^{-1})(30 \text{ cm}^3)(T_2 - 30^\circ\text{C}) = (2160 \times 10^{-6})(T_2 - 30)$$

$$\text{Or } 0.5 = (2.160 \times 10^{-3})(T_2 - 30)$$

$$\text{Or } 0.5 = (2.160 \times 10^{-3})(T_2 - 30)$$

$$\text{Or } 0.5 / (2.160 \times 10^{-3}) = T_2 - 30$$

$$\text{Or } 0.23 \times 10^3 = T_2 - 30$$

$$\text{Or } 0.23 \times 1000 = T_2 - 30$$

$$\text{Or } 230 = T_2 - 30$$

$$\text{Or } 230 + 30 = T_2$$

$$\text{Or } T_2 = 260^\circ\text{C}$$

## 7.9 Work and heat: -

**Heat** and **work** are two different ways of transferring energy from one system to another. The distinction between **Heat** and **Work** is important in the field of thermodynamics. **Heat** is the transfer of thermal energy between systems, while **work** is the transfer of mechanical energy between two systems. So, heat and work should be interconvertible. It is a matter of common experience that the two palms become hot if we rub them against each other. In this case work done gets converted into heat. Also due to heat supply, the steam engine works with mechanical motion.

## 7.10 Joules mechanical equivalent of heat.

Dr James Prescott Joule after a series of experiments concluded that there is equivalence between work and heat. According to Joule "whenever heat is converted into work or work into heat, the quantity of energy disappearing in one

form is equivalent to the quantity of energy appearing in the other.”

If an amount of work  $W$  results in the production of amount of heat  $H$ , the mechanical work done is directly proportional to the heat produced in the system.

$$W \propto H$$

$$\Rightarrow W = JH$$

Where  $J$  is the proportionality constant called as Joules mechanical equivalent of heat.

$$\text{If } H = 1 \quad \Rightarrow W = J$$

**Hence, Joules mechanical equivalent of heat is defined as the amount of work required to produce a unit quantity of heat.**

$$J = \frac{W}{H}$$

UNIT: The value of  $J = 4.2 \text{ J Cal}^{-1}$

### 7.11 First law of thermodynamics

Consider some gas enclosed in a barrel having insulating walls and conducting bottom. Let an amount of heat  $Q$  be added to the system through the bottom.

If,  $U_1$  is the initial internal energy of the system then,

Total energy of the system in the beginning =  $U_1 + Q$

After gaining heat the gas tends to expand, pushing the piston upward as shown in the figure 7.6. As a result of this, some work  $W$  is done by the gas. The work is external work, since the system undergoes a displacement.

If  $U_2$  is the final internal energy of the system then,

Total energy of the system at the end =  $U_2 + W$

Change in internal energy =  $U_2 - U_1 = \Delta U$

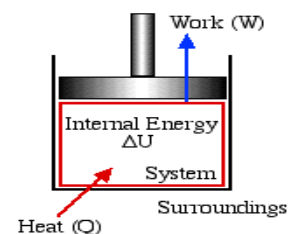

According to the law of conservation of energy

Fig. 7.6

$$U_1 + Q = U_2 + W$$

$$\Rightarrow Q = (U_2 - U_1) + W$$

$$\Rightarrow Q = \Delta U + W$$

**Statement:** - The first law of thermodynamics states that “if the quantity of heat supplied to a system is capable of doing some work, then the quantity of heat absorbed by the system is equal to the sum of the increase in internal energy of the system and external work done by it.”

## EXERCISE

### VERY SHORT ANSWER QUESTIONS (2 Marks each)

1. What is the unit of coefficient of linear expansion?

Ans : unit of coefficient of linear expansion in S.I is  $K^{-1}$  and in C.G.S  $^{\circ}C^{-1}$ .

2. How are  $\alpha$  and  $\beta$  related to each other?

Ans :  $\beta = 2\alpha$ . Hence  $\alpha = \beta / 2$ .

3. Define Joule's mechanical equivalent of heat.

Ans : Joule's mechanical equivalent of heat is defined as the amount of work required to produce a unit quantity of heat.

$$J = \frac{W}{H}$$

4. Define specific heat.

5. What is latent heat? Write its unit and dimension.

### SHORT ANSWER QUESTIONS (5 Marks each)

6. Illustrate the phenomenon of thermal expansion with the help of two examples.
7. Define coefficient of superficial expansion and cubical expansion. How are they related to each other?
8. Obtain a relation between (i)  $\alpha$  and  $\beta$  (ii)  $\alpha$  and  $\gamma$
9. State the first law of Thermodynamics.
10. How do you define Joule's mechanical equivalent of heat? What is its value in SI units?

### LONG ANSWER QUESTIONS (10 Marks each)

1. (a) Define coefficient of linear expansion and coefficient of superficial expansion of a material. Obtain a relation between the two.

(b) The length of a rod at  $0^{\circ}C$  is 1m. Calculate its length at  $100^{\circ}C$ .

Coefficient of linear expansion of material  $1.5 \times 10^{-5} C^{-1}$

Ans of (b):

The length of a rod at  $0^{\circ}C = L_0 = 1m = 100cm$

Change in Temperature ( $\Delta T$ ) =  $T_1 - T_2 = 100^{\circ}C - 0^{\circ}C = 100^{\circ}C$

Coefficient of linear expansion of material ( $\alpha$ ) =  $1.5 \times 10^{-5} C^{-1}$

Final length at  $100^{\circ}C = L_t = L_0(1 + \alpha\Delta T) = 100 \times [1 + (1.5 \times 10^{-5} \times 100)] = 100.$

15c.m = 1.0015 m

## UNIT- 8

### OPTICS

*Optics is a branch of physics that deals with the determination of behaviour and the properties of light.* You rely on optics every day. Your digital camera, wireless mouse, and even your Blu-ray disc of your favourite movie are all technologies enabled by the science of optics.

As light presents a dual behaviour, which can be considered as a wave or particle, basically there are two types of optics:

- **Physical optics** - when considering the wave nature of light.
- **Geometric optics** - when light is considered a particle and its studies are based on the concept of light rays.

Ray optics or geometrical optics describes light propagation in terms of "rays", which travel in a straight line. A light wave can be considered to travel from one point to another, along a straight line. The path is called a ray of light, and a bundle of such rays constitutes a beam of light. In this chapter, we will discuss the phenomena of reflection, refraction and dispersion of light, using the ray picture of light. Using the basic laws of reflection and refraction, we shall study the refractive index, refraction through prism, total internal reflection and critical angle. We then go on to describe the construction and working of some important optical instruments like optical fibre.

#### 8.1 Reflection and Refraction: -

##### Reflection

**Reflection:** The phenomenon of light by virtue of which a ray of light moving from a medium to another medium is sent back to the same medium from the interface between the two media is called as reflection.

**Incident ray:** The ray of light falling on the surface of a mirror is called incident ray.

**Point of incidence** -The point at which the incident ray falls on the mirror surface is called point of incidence.

**Reflected ray:** The ray of light which is sent back by the mirror from the point of incidence is called reflected ray.

**Normal:** A line perpendicular or at the right angle to the mirror surface at the point of incidence is called normal.

**Angle of incidence:** The angle made by the incident ray with the normal is called angle of incidence.

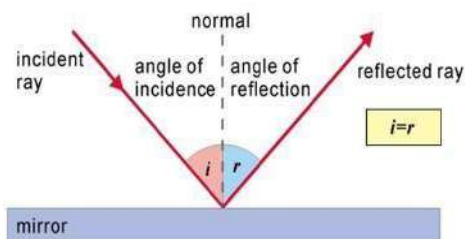

Fig.8.1

**Angle of reflection:** The angle made by the reflected ray with the normal at point of incidence is called angle of reflection.

The intensity of the reflected ray depends upon the nature, state of polish and smoothness of the reflecting surface.

## .Refraction

**Refraction:-** The phenomenon of light by virtue of which a ray of light moving from one medium to another medium undergoes a change in its velocity is called as refraction.

**Incident ray:** The ray of light falling on the interface is called incident ray.

**Point of incidence:** The point at which the incident ray falls on the interface is called point of incidence.

**Refracted ray:** The ray of light which travels to the second medium from the point of incidence is called reflected ray.

**Normal:** A line perpendicular or at the right angle to the interface at the point of incidence is called normal.

**Angle of incidence:** The angle made by the incident ray with the normal is called angle of incidence.

**Angle of refraction:** The angle made by the refracted ray with the normal at point of incidence is called angle of refraction.

If light travels from an optically rarer medium to a denser medium, it bends towards the normal, i.e. angle of refraction ( $r$ ) is less than angle of incidence ( $i$ ). If light travels from an optically denser medium to a

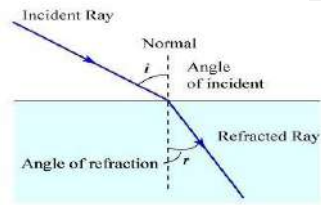

rarer medium, it bends away from normal, i.e., angle of refraction is greater than angle of incidence ( $i$ ). Fig.8.2

## **8.2 Laws of Reflection and Refraction: -**

### **Laws of Reflection: -**

Laws of reflection state that:

**First law:** The incident ray, the reflected ray and the normal to the reflecting surface at the point of incidence, all lie in one plane and that plane is perpendicular to the reflecting surface as shown in Fig. 8.1

**Second law:** The angle of incidence is equal to the angle of reflection. i.e.,  $i = r$

### **Laws of Refraction: -**

Laws of refraction state that:

- The incident ray, the refracted ray and the normal to the interface at the point of incidence, all lie in one plane and that plane is perpendicular to the interface separating the two media as shown in Fig. 8.2
- The ratio of the sine of the angle of incidence to the sine of the angle of refraction is a constant. This is also known as Snell's law of refraction.

$$\frac{\sin i}{\sin r} = \text{constant}$$

This is also known as Snell's law of refraction.

### 8.3 Refractive index:-

Refractive index is the property of a medium/material that measure the optical density of that medium and it describes how fast light travels through that medium.

According to Snell's law,

$$\frac{\sin i}{\sin r} = \text{constant} = \frac{1}{\mu_2} \dots\dots\dots (1)$$

Where  $\mu_2$  is a constant, called the refractive index of the second medium with respect to the first medium and it is defined as the ratio of sine of the angle of incidence to sine of the angle of refraction.

If  $v_1$  and  $v_2$  are the velocities of light in 1<sup>st</sup> and 2<sup>nd</sup> medium respectively, then

$$\mu_2 = \frac{v_1}{v_2} \dots\dots\dots (2)$$

Hence It can also be defined in an alternative form as, the ratio of velocity of light in first medium to the velocity of light in second medium.

If the first medium is air or vacuum, the refractive index is written as  $\mu$  and is known as the absolute refractive index. i.e.,

$$\mu = \frac{c}{v} \dots\dots\dots (3)$$

where  $c$  is the speed of light in vacuum and  $v$  is the speed of light in the medium.

Dividing the numerator and denominator of equation (2) by  $c$ , we get

$$\mu_2 = \frac{v_1/c}{v_2/c} = \frac{1/\mu_1}{1/\mu_2} = \mu_2 / \mu_1 \dots\dots (4)$$

According to equation (4), refractive index of second medium with respect to first medium is defined as the ratio of absolute refractive index of second medium to absolute refractive index of first medium.

The refractive index of other materials can be calculated from the above equation. Higher the refractive index, higher the optical density and slower is the speed of light. i.e., the medium having smaller refractive index value is optically rarer and the medium having greater refractive index value is optically denser. The vacuum has a refractive index of 1 (minimum value of refractive index).

Refractive index is a unit-less and dimensionless constant. The table below lists the refractive index of different media.

Example 1: Refractive index of water w.r.t air is  $\frac{4}{3}$ , while that of glass is  $\frac{3}{2}$ . What will be the Refractive index of glass w.r.t water.

Solution: we know that

$$1\mu_2 = \mu_2 / \mu_1 \Rightarrow {}^w\mu_g = \frac{\mu_g}{\mu_w} = \frac{3}{2} \times \frac{3}{4}$$

$$\Rightarrow {}^w\mu_g = \frac{9}{8}$$

Example 2: A ray of light travelling in water is incident at an angle of  $30^\circ$  on water glass surface. Calculate the angle of refraction in glass, if absolute refractive index of water is  $\frac{4}{3}$  and that of glass is  $\frac{3}{2}$ .

**Solution:** According to Snell's law,

$$\frac{\sin i}{\sin r} = {}^w\mu_g \quad \dots (1)$$

$$\text{But } {}^w\mu_g = \frac{\mu_g}{\mu_w} = \frac{3}{2} \times \frac{3}{4} = \frac{9}{8}$$

Again, angle of incidence  $i = 30^\circ$

$$\Rightarrow \frac{\sin 30^\circ}{\sin r} = \frac{9}{8}$$

$$\Rightarrow \sin r = \frac{8}{9} \times \sin 30^\circ = \frac{8}{9} \times \frac{1}{2} = \frac{4}{9} = 0.4444$$

$$\Rightarrow r = 26.4^\circ$$

Hence angle of refraction is  $26.4^\circ$ .

## 8.4 Critical angle and Total internal reflection:-

A good-quality mirror may reflect more than 90% of the light that falls on it, absorbing the rest. But it would be useful to have a mirror that reflects all of the light that falls on it. Interestingly, we can produce *total reflection* using an aspect of *refraction*.

Consider a source of light  $S$  situated in a denser medium say water as shown in the Fig. 8.3 Rays starting from  $S$  travel from water to air, i.e., from denser to rarer medium. First ray incident normally on the interface goes undeviated. Again, the next rays are incident on the interface at gradually increasing angles of incidence. Therefore, they deviate more and more away from the normal. Now, one ray is incident at a particular angle of incidence  $C$  such that refracted ray is parallel to the surface, i.e., angle of refraction,  $r = 90^\circ$ . This angle of incidence  $C$  is the critical angle.

### Critical angle:

Critical angle is defined as the angle of incidence in optically denser medium for which angle of refraction in the optically rarer medium is  $90^\circ$ .

If the angle of incidence of the ray increased further, i.e., greater than critical angle, it is reflected back into the same medium. This phenomenon is called as Total Internal Reflection.

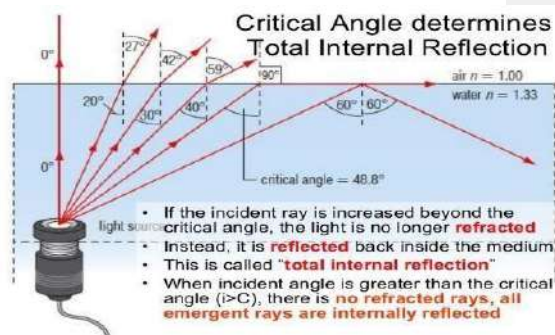

Fig 8.3

**Total Internal Reflection:-**

Total internal reflection is the phenomenon by virtue of which a ray of light traveling from a optically denser medium to a rarer medium is sent back to the same medium when the ray is incident at an angle more than the critical angle for that medium.

**Conditions for total internal reflection:-**

- Light ray must be travel from denser to rarer medium.
- Angle of incidence must be greater than critical angle.

**Relation between critical angle and refractive index: -**

For the fifth ray in the above diagram (Fig 8.3), angle of incidence = C (critical angle)

For this, angle of refraction, r = 90°

According to Snell's law, refractive index of 1<sup>st</sup> medium w.r.t 2<sup>nd</sup>medium, is given by

$${}^2\mu_1 = \frac{\sin C}{\sin 90} = \frac{\sin C}{1} = \sin C$$

Taking reciprocal/inverse of both the sides, we get

$$\therefore \frac{1}{{}^2\mu_1} = \frac{1}{\mu_2} = \frac{1}{\sin C} \quad r = 90^\circ$$

If the first medium is air or vacuum, we can write

that the refractive index of 2<sup>nd</sup>medium w.r.t. 1<sup>st</sup> medium is given as

$${}^1\mu_2 = \mu_2$$

Hence, absolute refractive index of 2<sup>nd</sup> medium is  $\mu = \frac{1}{\sin C}$

Therefore, the absolute refractive index of a medium is equal to the reciprocal of the sine of the critical angle for that medium.

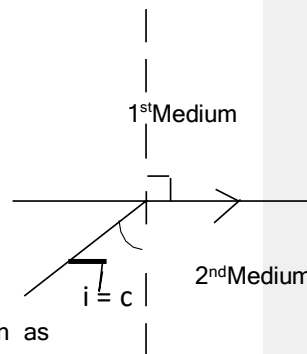

Fig. 8.4

Example 1: The critical angle of incidence of a glass slab immersed in air is  $30^\circ$ .

What will be the critical angle when it is immersed in medium of refractive index  $\sqrt{2}$ ?

Solution: In case of glass in air

$$\sin C = \frac{1}{{}^a\mu_g}$$

Here,  $C = 30^\circ$

$$\Rightarrow \sin 30^\circ = \frac{1}{{}^a\mu_g} \Rightarrow \frac{1}{2} = \frac{1}{{}^a\mu_g}$$

$$\Rightarrow {}^a\mu_g = 2$$

In case of glass placed in another medium,

$$\sin C_m = \frac{1}{{}^m\mu_g} = \frac{1}{{}^m\mu_a \times {}^a\mu_g} = \frac{{}^a\mu_m}{{}^a\mu_g}$$

$$\text{Here } {}^a\mu_m = \sqrt{2}$$

$$\Rightarrow \sin C_m = \frac{\sqrt{2}}{2} = \frac{1}{\sqrt{2}}$$

$$\Rightarrow C_m = 45^\circ$$

Example 1: What is the critical angle for a ray going from glass to water? The refractive indices of glass and water are 1.62 and 1.32 respectively.

Solution: If  $C$  is the critical angle for a ray going from glass to water, then

$$\sin C = \frac{1}{{}^w\mu_g} = {}^g\mu_w$$

$$\text{But } {}^g\mu_w = \frac{\mu_w}{\mu_g} = \frac{1.32}{1.62} = 0.8148$$

$$\Rightarrow \sin C = 0.8148 \Rightarrow C = \sin^{-1}(0.8148) = 54.57^\circ$$

## Refraction through a prism: -

The ray of light is incident on one of the refracting faces of prism and proceeds through the prism.

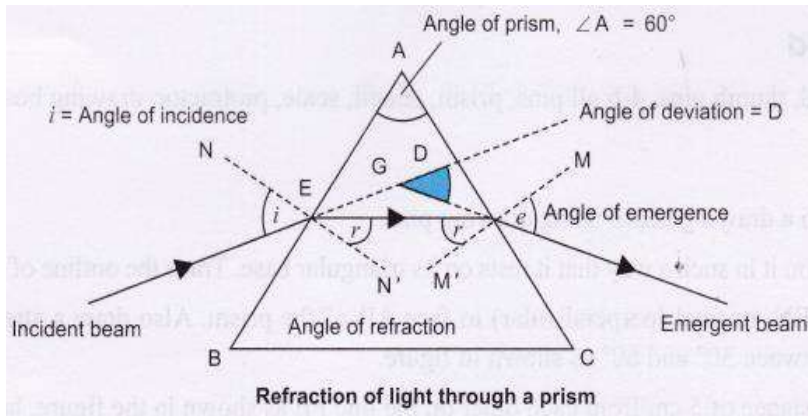

Fig. 8.5

ABC is the prism

A is the angle of prism

i is the angle of incidence

r<sub>1</sub> is the angle of refraction

e is the angle of emergence

D is the angle of deviation

D<sub>m</sub> is the angle of minimum deviation

AB and AC are two refracting faces of prism

Then refractive index of the material of prism is given by,

$$\mu = \frac{\sin\left(\frac{A+D_m}{2}\right)}{\sin\frac{A}{2}}$$

## Optical Fiber:-

Optical fibre is the technology associated with data transmission using light pulses travelling along with a long fibre which is usually made of plastic or glass. Metal wires are preferred for transmission in optical fibre communication as signals travel with fewer damages. Optical fibres are also unaffected by

electromagnetic interference. The fibre optical cable uses the application of total internal reflection of light. The fibres are designed such that they facilitate the propagation of light along with the optical fibre depending on the requirement of power and distance of transmission.

The optical fibre works on the principle of Total Internal Reflection(TIR). Light rays can be used to transmit a huge amount of data, but there is a problem here - the light rays travel in straight lines. So, unless we have a long straight wire without any bends at all, harnessing this advantage will be very tedious. Instead, the optical cables are designed such that they bend all the light rays inwards (using TIR). Light rays travel continuously, bouncing off the optical fibre walls and transmitting end to end data. Although light signals do degrade over progressing distances, depending on the purity of the material used, the loss is much less compared to using metal cables.

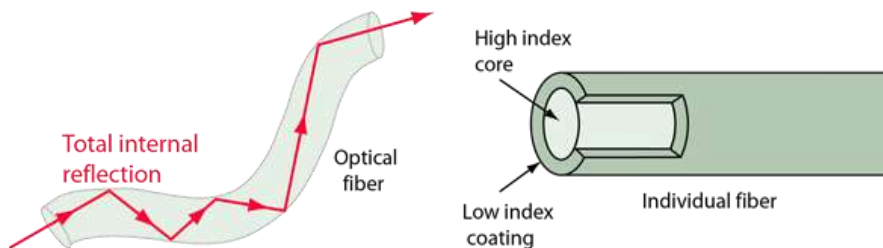

**Definition:**

Fig 8.6

An **optical fiber** is a dielectric cylindrical wave guide consisting of two layers, i.e., core and a surrounding cladding. The refractive index of the material of the core is higher than that of the cladding. Both are made up of thin, flexible, high quality, transparent fiber of glass or plastic, where light undergoes successive total internal reflections along the length of the fibre and finally comes out at the other end (Fig. 8.7). The study of **optical fiber** is called **fiberoptics**.

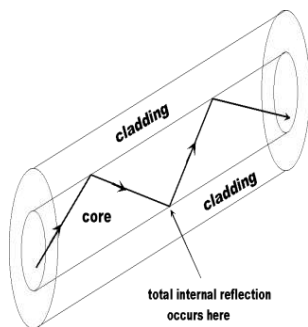

Fig 8.7

Since light undergoes total internal reflection at each stage, there is no appreciable loss in the intensity of the light signal. Optical fibers are fabricated such that light reflected at one side of inner surface strikes the other at an angle larger than the critical angle. Even if the fibre is bent, light can easily travel along its length. Thus, an optical fibre can be used to act as an optical pipe.

#### Properties:-

- It has a large bandwidth. The optical frequency of  $2 \times 10^{14}$  Hz can be used and hence the system has higher bandwidth. Thus, optical fiber have greater information-carrying capacity due to greater bandwidth and they permit transmission over longer distances and at higher [bandwidths](#) (data transfer rates) than electrical cables.
- Optical fibers are small in size and have lightweights as compared to electrical cables. They are flexible and have very high tensile strength. Thus, they can be twisted and bent easily.
- Optical fiber provides a high degree of signal securities as it is confined to the inside of fibre and can not be tapped and tempered easily. Thus, it satisfies the need for security which is required in banking and defence.
- Optical fiber communication is free from electromagnetic interference.
- Optical fiber material does not carry high voltage or current. Hence, they are safer than electrical cable.

## Applications:

Some of the major application areas of optical fibers are:

- Communications- for transmitting audio and video signals through long distances. Voice, data, and video transmission are the most common uses of fiber optics, and these include, telecommunications, local area networks (LANs), industrial control system.
- Sensing – Fiber optics can be used to deliver light from a remote source to a detector to obtain pressure, temperature, or spectral information. The fiber also can be used directly as a transducer to measure a number of environmental effects, such as strain, pressure, electrical resistance etc. Environmental changes affect the light intensity, phase and/or polarization in ways that can be detected at the other end of the fiber.
- Power Delivery – Optical fibers can deliver remarkably high levels of power for tasks such as lasercutting, welding, marking, and drilling.
- Illumination – A bundle of fibers gathered together with a light source at one end can illuminate areas that are difficult to reach, for example in medical field, inside the human body, in conjunction with an endoscope.
- Optical fibers are used instead of [metal](#) wires because signals travel along them with less loss.
- Optical fibers are extensively used for transmitting and receiving electrical signals which are converted to light by suitable transducers. For example, these are used as a "light pipe" to facilitate visual examination of internal organs like oesophagus, stomach, and intestines
- Available decorative lamps having fine plastic fibres with their free ends forming a fountain like structure, have the end of the fibers is fixed over an electric lamp. When the lamp is switched on, the light travels from the bottom of each fiber and appears at the tip of its free end as a dot of light. The fibers in such decorative lamps are optical fibres.

## EXERCISE

### VERY SHORT ANSWER QUESTIONS(2 Marks each)

1. How are the angle of incidence and angle of refraction related to each other?
2. What is refractive index?
3. Refractive index of glass and water are respectively 1.5 and 1.3. Which of them is denser optically?
4. What is critical angle?
5. Define total internal reflection?
6. What are the conditions for total internal reflection?

### SHORT ANSWER QUESTIONS (5 Marks each)

7. Draw a ray diagram showing reflection at a plane interface. Separating the two media and mark angle of incidence and angle of refraction.
8. State the Laws of refraction.
9. How do you define refractive index of medium 2 with respect to medium 1 in terms of (i) velocity of light in the two media (ii)The absolute refractive indices of the two media.
10. Velocity of light in vacuum is  $3 \times 10^8$  m/s. What will be its velocity in glass, if its refractive index is 1.5?
11. Explain the principle of working of an optic fiber.
12. Define critical angle and state how it is connected with refractive index of a medium?
13. Define reflection and state the laws of reflection.

### LONG ANSWER QUESTIONS (10 Marks each)

1. (a) What is the phenomenon of total internal reflection? State and explain the conditions in which it can take place.  
(b)Refractive index of water with respect to air is  $4/3$ . calculate its critical angle.
2. How do you define refractive index for a medium with respect to another? Give two definitions.
3. Velocity of light in a medium is found to be  $2.25 \times 10^8$  m/s.Calculate its absolute refractive index. Velocity of light in vacuum is  $3 \times 10^8$  m/s

# UNIT-9

## ELECTROSTATICS & MAGNETOSTATICS

### 9.1 Electrostatics

All of us have the experience of seeing a spark or hearing a crackle when we take off our synthetic clothes or sweater, particularly in dry weather. Have you ever tried to find any explanation for this phenomenon? You might have heard that this is due to generation of static electricity. This is precisely the topic we are going to discuss in this chapter. Static means anything that does not move or change with time.

Electrostatics is the study of properties of stationary or slow-moving electric charges. Electrostatic phenomena arise from the forces that electric charges exert on each other. It deals with the study of forces, fields and potentials arising from static charges.

### 9.2 Coulomb's law in Electrostatics

Coulomb's law is a quantitative statement about the force between two-point charges. When the linear size of charged bodies are much smaller than the distance separating them, the size may be ignored, and the charged bodies are treated as point charges.

**Statement-** It states that "The force between two-point charges is directly proportional to the product of the magnitude of the two charges and inversely proportional to the square of the distance between the charges and acts along the line joining the two charges".

**Explanation:**

The force is along the straight line joining them. If the two charges have the same sign, the electrostatic force between them is repulsive; if they have different signs, the force between them is attractive.

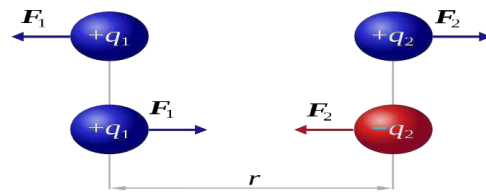

**Fig 9.1**

Consider two-point charges  $+q_1$ ,  $-q_2$  which are separated by a distance  $r$ , then the magnitude of the force ( $F$ ) between them is given by

$$F \propto |q_1||q_2|$$

$$F \propto \frac{1}{r^2}$$

$$F = \beta \frac{|q_1||q_2|}{r^2}$$

Where  $\beta$  is the constant of proportionality and its value depends on the nature of the medium in which two charges are situated.

In C.G.S. system,

$$\beta = \frac{1}{k}$$

Where  $k$  is called as the dielectric constant of the medium and is defined as the ratio of the force between two charge particles separated by some distance apart in free space to the force between the same two charge particles separated by same distance apart in that medium. It is a dimensionless constant.

Hence,

$$F = \frac{1}{k} \frac{|q_1||q_2|}{r^2}$$

Or

$$F = \frac{|q_1||q_2|}{r^2} \text{ (as } k = 1 \text{ for free space)}$$

In S.I. System,

$$\beta = \frac{1}{4\pi\epsilon_0 K}$$

Where  $\epsilon_0$  is called the permittivity of free space and the value of  $\epsilon_0$  in SI units is  $\epsilon_0 = 8.854 \times 10^{-12} \text{ C}^2 \text{ N}^{-1} \text{ m}^{-2}$ .

In free space,  $K=1$

$$\Rightarrow F = \frac{1}{4\pi\epsilon_0} \frac{|q_1||q_2|}{r^2} = \frac{1}{4\pi\epsilon_0} \frac{|q_1||q_2|}{r^2}$$

And  $\frac{1}{4\pi\epsilon_0} = 9 \times 10^9 \text{ N.m}^2\text{C}^{-2}$

**Unit Charge:-**

(i) **In C.G.S. system:**

From Coulomb's law, we have,

$$\text{In air } F = \frac{|q_1||q_2|}{r^2} \dots\dots\dots(1)$$

If  $q_1 = q_2 = q$  (say),  $r = 1$  cm and  $F = 1$  dyne, then from (1) we get

$$1 = \frac{q^2}{1} \text{ or } q^2 = 1$$

$\therefore q = \pm 1$  statcoulomb (in e.s.u);

e.s.u - electrostatic system of unit

Hence unit charge or statcoulomb is the amount of charge which when placed in air at a distance of 1 cm from a similar charge repels it with a force of 1 dyne.

(ii) **In S.I. System**

From Coulomb's law, we have,

$$\text{In air, } F = \frac{1}{4\pi\epsilon_0} \frac{q_1q_2}{r^2} \dots\dots\dots (2)$$

If  $q_1 = q_2 = q$  (say),  $r = 1$  metre, and  $F = 9 \times 10^9$  Newton, then from (2) we get

$$9 \times 10^9 = \frac{1}{4\pi\epsilon_0} \frac{q^2}{1} = (9 \times 10^9) \times q^2$$

$$\Rightarrow q^2 = 1$$

$$\Rightarrow q = \pm 1 \text{ Coulomb}$$

Hence unit charge or 1 Coulomb is the amount of charge which when placed in air at a distance of 1 metre from a similar charge repels it with a force of  $9 \times 10^9$  Newton.

$$1 \text{ Coulomb} = 3 \times 10^9 \text{ statcoulomb}$$

**9.3 Absolute and Relative permittivity:**

**Permittivity is defined as the ability of a substance to store electrical energy in an electric field or the ability of a material to store electrical potential energy under the influence of an electric field.**

Absolute permittivity is denoted by the Greek letter  $\epsilon$  (epsilon) and the relative permittivity is denoted by Greek letter  $\epsilon_r$ . Relative permittivity is same as dielectric constant.

The relative permittivity of a medium  $\epsilon_r$  is defined as the ratio of the absolute permittivity of the medium  $\epsilon$  and the permittivity of free space  $\epsilon_0$ .

It is written as,

$$\epsilon_r = \frac{\epsilon}{\epsilon_0}$$

$$\therefore \epsilon = \epsilon_r \epsilon_0$$

**Unit: -**

**From Coulomb's law, the force between two charges is**

$$F = \frac{1}{4\pi\epsilon_0} \frac{q_1 q_2}{r^2}$$

$$\Rightarrow \epsilon_r = \frac{1}{4\pi F} \frac{q_1 q_2}{r^2}$$

**Now, substituting the SI unit of all quantities on right hand side, the unit of permittivity we get,**

$$\epsilon_r = \frac{\text{coulomb} \times \text{coulomb}}{\text{Newton} \times \text{metre}^2} = \text{C}^2 \text{N}^{-1} \text{m}^{-2}$$

#### **9.4 Electric Potential:**

All of us know that the like charges repel each other and unlike charges attract each other. Some work is always involved in moving a charge in the area of another charge. What makes the charge to flow? This basically happens because of the Electric Potential.

If two charged bodies are in contact, the charge starts flowing from one conductor to other. The condition, that determines the flow of charge from one conductor to other in contact, is the **electric potential**. Earth is a conductor that can hold an infinite charge and can give infinite charge without changing its potential. Its potential is taken as zero potential.

**Definition:** The electrical potential is defined as the capability of the charged body to do work. When the body is charged, either electrons are supplied to it, or they are removed from it. In both the cases, the work is done. This work is stored in the body in the form of electric potential.

$$\text{Electric potential} = \frac{\text{work done}}{\text{charge}}$$

**Electric potential due to charge 'Q' at a point is defined as the work done in bringing the unit positive charge or test charge 'q<sub>0</sub>' from infinity to that point.**

Unit positive charge is regarded as test charge q<sub>0</sub>

$$V = \frac{1}{4\pi\epsilon_0} \frac{Q}{r} \quad (V \text{ is the electric potential at point } p)$$

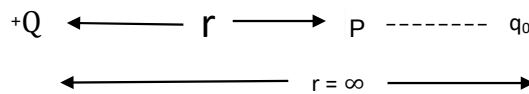

Fig. 9.2

**Units:** Since the work done is measured in joules and charge in coulombs, the unit of electric potential is **joules/coulomb** or **volts**.

If,  $W = 1 \text{ joules}; Q = 1 \text{ coulomb}$

$$V = \frac{1}{1} = 1 \text{ volt}$$

Hence a body is said to have an electrical potential of 1 volt if one joule of work is done to charge the body to one coulomb.

**Electric Potential Difference:**

When the current flows between two points A and B of an electric circuit as shown in the fig 9.3 below. We only consider the charge between the points A and B. This means it is not necessary to know the exact potential at each point A and B. It is sufficient to know the potential difference between the two points A and B which is defined as follows

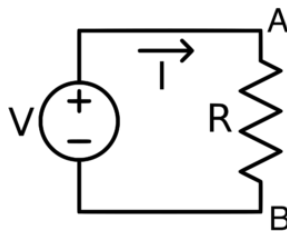

Fig 9.3

**Definition:** The electrical potential difference is defined as the amount of work done to carry a unit positive charge from one point to another in an electric field. In other words, the potential difference is defined as the difference in the electric potential of the two charged bodies.

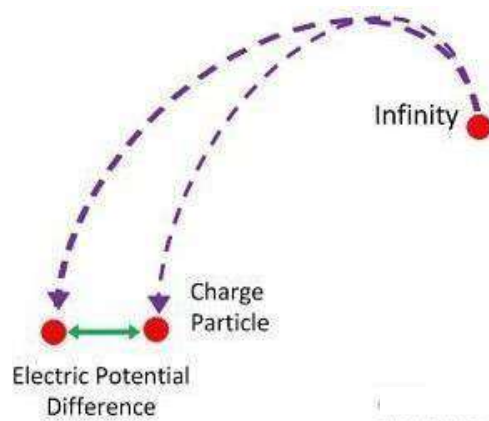

Fig 9.4

When a body is charged to a different electric potential as compared to the other charged body, the two bodies are said to have a potential difference. The potential difference between two points is said to be 1 volt if the work is done in moving 1-coulomb of charge from one point to other is 1 joule.

$$1 \text{ volt} = \frac{1 \text{ Joule}}{1 \text{ coulomb}}$$

S.I unit for measuring the potential difference is volt and instrument used for measuring potential difference is a **voltmeter**. While connecting voltmeter in the circuit, positive terminal of the voltmeter should be in connection with the positive terminal of the cell and negative with the negative of the cell.

### 9.5 Electric field and electric field intensity(E):

An electric field is the physical field that surrounds each electric charge and exerts force on all other charges in the field, either attracting or repelling them. Electric fields originate from electric charges, or from time-varying magnetic fields.

#### Electric field Intensity(Electric field strength): -

The electric field intensity at any point inside an electric field is defined as the force experienced by the unit positive charge (test charge) placed at that point.

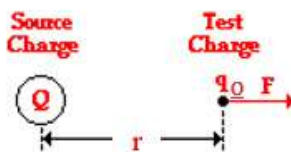

Fig. 9.5

Electric field intensity,

$$E = \frac{F}{q_0}$$

Where Q is the source charge and  $q_0$  is the test charge.

From Coulomb's law we know

$$F = \frac{1}{4\pi\epsilon_0} \frac{Q q_0}{r^2}$$

Hence,

$$E = \frac{\frac{1}{4\pi\epsilon_0} \frac{q_0}{r^2}}{q_0}$$

Or

$$E = \frac{1}{4\pi\epsilon_0} \frac{Q}{r^2}$$

The S.I unit of electric field intensity is Newton/Coulomb or N/C.

### 9.6 Capacitance

**Capacitance** is the property of an electric conductor, or set of conductors, that is measured by the amount of separated electric charge that can be stored on it per unit change in electrical potential.

It is denoted as C and is the ratio of the amount of electric charge stored on the conductor to the difference in electric potential

or

$$C = \frac{Q}{V}$$

If  $V = 1$  unit,  $\Rightarrow C = Q$

Hence **capacity or capacitance of a conductor is defined as the amount of charge required to raise the potential through one unit.**

In S.I system, the unit of electric charge is the coulomb and the unit of potential difference is the volt, so that the unit of capacitance is farad (symbolized F)—is one coulomb per volt.

$$\text{i.e. } 1 \text{ Farad} = \frac{\text{coulomb}}{\text{volt}}$$

### 9.7 series and parallel combination of capacitors

We can combine several capacitors of capacitance  $C_1, C_2, \dots, C_n$  to obtain a system with some effective capacitance  $C$ . The effective capacitance depends on the way the individual capacitors are combined. Two simple possibilities are discussed below.

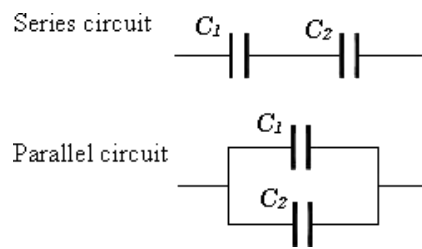
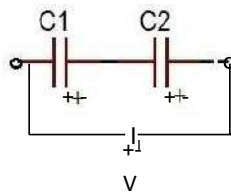

Fig 9.6

### Capacitors in series:

Capacitors in series means two or more capacitors are connected in a single line i.e., positive plate of the one capacitor is connected to the negative plate of the next capacitor. All the capacitors in series have equal charge ( $Q$ ) and distribution of potential takes place i.e.,  $V = V_1 + V_2 + \dots$

The following circuits show the series connection of group of capacitors.



Series connection of two capacitors

Fig 9.7

$$C_1 = Q / V_1, C_2 = Q / V_2$$

$$\Rightarrow V_1 = Q / C_1, V_2 = Q / C_2$$

$$\text{Hence, } V = V_1 + V_2 = Q / C_1 + Q / C_2 = Q ( 1 / C_1 + 1 / C_2 )$$

$$\Rightarrow V / Q = 1 / C_1 + 1 / C_2$$

$$\Rightarrow 1 / C = 1 / C_1 + 1 / C_2$$

Hence the reciprocal of equivalent capacitance is equal to the sum of reciprocal capacitances values of two capacitors  $C_1$  and  $C_2$ , the expression is given below.

$$\frac{1}{C_{eq}} = \frac{1}{C_1} + \frac{1}{C_2}$$

$$\Rightarrow \frac{1}{C_{eq}} = \frac{C_1 + C_2}{C_1 C_2}$$

$$\Rightarrow C_{eq} = \frac{C_1 C_2}{C_1 + C_2}$$

Where,  $C_{eq}$  = Equivalent or effective Capacitance of series connection

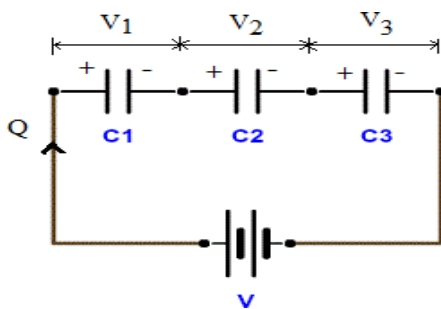

Fig 9.8

$$\frac{1}{C_{eq}} = \frac{1}{C_1} + \frac{1}{C_2} + \frac{1}{C_3}$$

Example No 1:

Two capacitors with capacities  $0.4\mu\text{F}$  and  $0.5\mu\text{F}$  are connected in series connection. Calculate the equivalent capacitance for the two capacitors in series.

Solution:

The equivalent capacitance for series connection is

$$\frac{1}{C_{eq}} = \frac{1}{C_1} + \frac{1}{C_2}$$

$$\Rightarrow \frac{1}{C_{eq}} = \frac{C_1 + C_2}{C_1 C_2}$$

$$\Rightarrow C_{eq} = \frac{C_1 C_2}{C_1 + C_2}$$

$$\Rightarrow C_{eq} = \frac{0.4\mu\text{F} \times 0.5\mu\text{F}}{0.4\mu\text{F} + 0.5\mu\text{F}}$$

$$\Rightarrow C_{eq} = 0.22\mu\text{F}$$

Capacitors in parallel:

Capacitors are said to be in parallel connection if the first plates (marked A) of all the capacitors are connected together to the positive terminal of the battery while the second plates (marked B) are connected together to the negative terminal of the battery.

All the capacitors which are connected in parallel have the same voltage and is equal to the voltage  $V$  applied between the input and output terminals of the circuit. Then, parallel capacitors have a common voltage supply across them. i.e.,  $V = V_1 = V_2$  etc, but distribution of charge takes place. i.e.,  $Q = Q_1 + Q_2 + Q_3 + \dots$

The following circuit in fig 9.9 shows parallel connection between groups of capacitors.

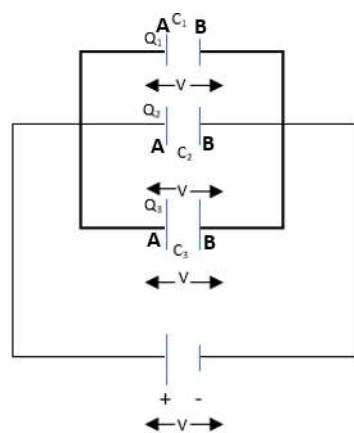

We know that,  $Q = CV$ ,  $Q_1 = C_1V$ ,  $Q_2 = C_2V$ ,  $Q_3 = C_3V$

Hence,  $Q = Q_1 + Q_2 + Q_3$

$\Rightarrow CV = C_1V + C_2V + C_3V \Rightarrow$

$C = C_1 + C_2 + C_3$

Hence,  $C_{eq} = C_1 + C_2 + C_3 + \dots$

Where  $C_{eq}$  = Equivalent capacitance of parallel combination.

Example No 1: The capacities of two capacitors are  $C_1 = 0.2\mu F$  and  $C_2 = 0.3\mu F$ .

Calculate the equivalent capacitance of the circuit for parallel connection.

Solution: The equivalent capacitance for parallel connection is

$$C_{eq} = C_1 + C_2$$

$$\Rightarrow C_{eq} = 0.2\mu F + 0.3\mu F$$

$$\Rightarrow C_{eq} = 0.5\mu F$$

## 9.8 Magnet

The word magnet is derived from the name of an island of Greece called magnesia where magnetic ore deposits were found. A magnet is a material or object which is capable of producing magnetic field and attracting unlike poles and repelling like poles.

There are three types of magnets, and they are as follows:

- Permanent magnet
- Temporary magnet
- Electromagnets

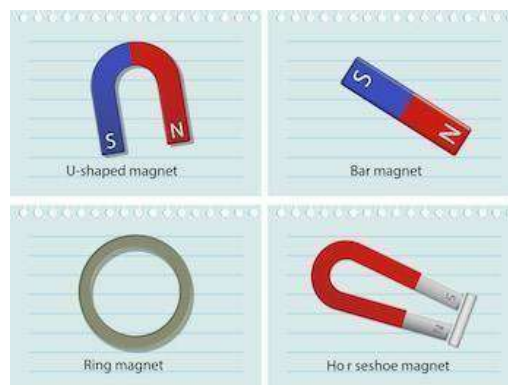

Fig 9.10

### Properties of magnet:

Following are the basic properties of magnet:

- When a magnet is dipped in iron filings, we can observe that the iron filings cling to the end of the magnet as the attraction is maximum at the ends of the magnet. These ends are known as poles of the magnets.
- Magnetic poles always exist in pairs.
- Whenever a magnet is suspended freely in mid-air, it always points towards north-south direction. Pole pointing towards geographic north is known as the North Pole and the pole pointing towards geographic south is known as the South Pole.
- Like poles repel while unlike poles attract.

- The magnetic force between the two magnets is greater when the distance between these magnets is lesser.

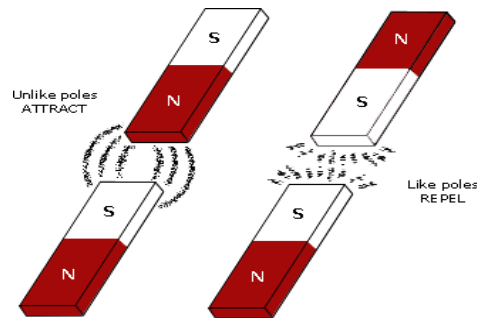

Fig 9.11

### 9.9 coulomb's law in magnetostatic

**Statement:**It states that “if two magnetic poles (isolated) of strength  $m_1$  and  $m_2$  are kept at a distance  $r$  apart, then force of attraction or repulsion between the two poles is directly proportional to the product of their pole strengths and inversely proportional to the square of the distance between them.”

**Explanation:**

Consider two magnetic poles of strength  $m_1$  and  $m_2$  separated by a distance  $r$  from each other as shown in the fig 9.12 given below. Then according to Coulomb's law, the force between them,

$$F \propto m_1 m_2$$

$$F \propto \frac{1}{r^2}$$

$$\Rightarrow F \propto \frac{m_1 m_2}{r^2}$$

$$F = k \frac{m_1 m_2}{r^2}$$

Where  $k$  is the constant of proportionality and its value depends on the nature of the medium in which two magnetic poles are situated.

In C.G.S. system,  $k = 1$

$$\Rightarrow F = \frac{m_1 m_2}{r^2}$$

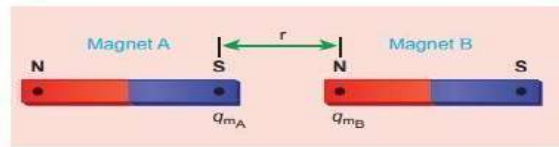

Coulomb's law – force between two magnetic pole strength

Fig 9.12

In S.I,  $k = \frac{\mu_0}{4\pi}$

$$\therefore F = \frac{\mu_0 m_1 m_2}{4 r^2}$$

Where  $\mu_0$  is called as the absolute magnetic permeability of free space.

And  $\mu_0 = 4\pi \times 10^{-7} \text{ Wb A}^{-1}\text{m}^{-1}$

**Unit pole: -**

(i) In C.G.S. system:

From Coulomb's law, we have,

$$F = \frac{m_1 m_2}{r^2} \dots \dots \dots (1)$$

If  $m_1 = m_2 = m$ (say),  $r = 1 \text{ cm}$  and  $F = 1 \text{ dyne}$ , then from (1) we get

$$1 = \frac{m^2}{1}$$

or  $m^2 = 1$

$$\therefore m = \pm 1$$

**Definition:** Hence unit pole is the pole which when placed in air at a distance of 1 cm from a similar pole repels it with a force of 1 dyne.

(ii) In S.I. System:

From Coulomb's law, we have,

$$F = \frac{\mu_0 m_1 m_2}{4\pi r^2} \dots\dots\dots (2)$$

Again,  $\mu_0 = 4\pi \times 10^{-7} \text{ Wb A}^{-1}\text{m}^{-1}$

$$\Rightarrow F = \frac{4\pi \times 10^{-7} m_1 m_2}{4\pi r^2} = \frac{10^{-7} m_1 m_2}{r^2}$$

If  $m_1 = m_2 = m$ (say),  $r = 1$  metre and  $F = 10^{-7}$  Newton, then from (2) we get

$$10^{-7} = 10^{-7} \times \frac{m^2}{1}$$

or  $m^2 = 1$

$$\therefore m = \pm 1$$

Hence unit pole is the pole which when placed in air at a distance of 1 metre apart from a similar pole repels it with a force of  $10^{-7}$ Newton.

**Definition:** A unit magnet pole is defined as one that exerts a force of  $10^{-7}$  newton on another magnetic pole of same strength when poles are separated from each other by a distance of one metre in free space.

**9.10 Magnetic field: -**

Magnetic Field is the region around a magnetic material or a moving electric charge within which the force of magnetism acts. We can say *magnetic field* is the area around a magnet, magnetic object, or a moving electric charge in which magnetic force is exerted.



Fig 9.13

**Magnetic field intensity (H):**

**Magnetic field strength**, also called **magnetic field intensity**. **Magnetic field intensity at any point inside the magnetic field is defined as the force**

experienced by a unit north pole at that point. The direction of field is the direction in which the unit pole would move if it is free to do so.

$$\Rightarrow H = \frac{F}{m} \quad (F = \text{magnetic force, } m = \text{unit pole strength})$$

### 9.11 Magnetic lines of force:

To describe the phenomena related to magnets, lines are used to depict the force existing in the area surrounding the magnet. These lines are called the magnetic lines of force. These lines do not exist in actual but are imaginary lines that are used to illustrate and describe the pattern of the magnetic field. As shown in the figure below, the magnetic lines of force are assumed to originate from the north pole of a magnet, then pass through the surrounding space and arrive at the South Pole. Then these lines travel inside the magnet from the South Pole to the North Pole and hence complete the loop.

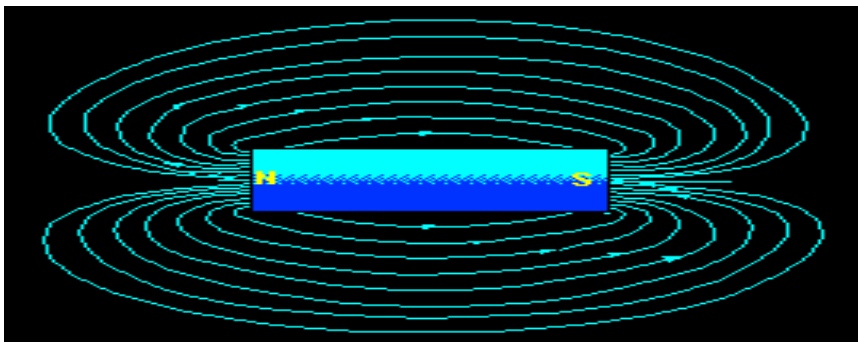

Fig 9.14

Two magnetic lines of force do not intersect with each other because if they do so, at the point of intersection, there will be two values of magnetic field at that point which is not possible. At the poles of the magnet the magnetic field is stronger because the lines of force there are crowded together and away from the poles the magnetic field strength decreases. i.e., magnetic field intensity depends on the number of lines of force.

In each of the following pictures a magnet is put onto a piece of paper. Then a light dusting of iron filings is sprinkled around the magnet. The lines around the magnets in the following pictures are produced by the iron filings gathering along the field lines.

Box A

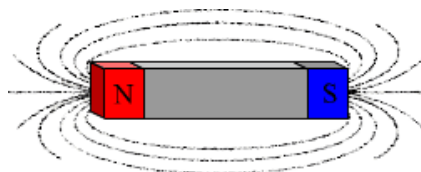

Fig 9.15

This picture demonstrates what occurs when one magnet is placed on paper, and iron filings are sprinkled around it.

Box B

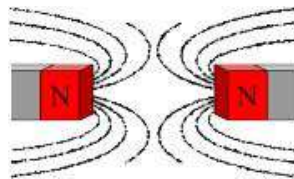

Fig 9.16

Pictured here are two magnets placed on a piece of paper with their like poles facing each other, and iron filings sprinkled around them.

Box C



Fig 9.17

Lastly, this picture has two magnets placed on a piece of paper with their opposite poles facing each other, and iron filings sprinkled around them.

**Definition:** Magnetic lines of force are the imaginary curves along which the unit north pole would move if it were free to do so.

**Properties of magnetic lines of force:**

The properties of magnetic lines of force are as follows.

- Outside the magnet, lines of forces start from north pole and ends at south pole and inside the magnet these are from south to north pole.
- Tangent drawn at any point on the lines of force gives the direction of the magnetic field at that point.
- Magnetic lines of force never intersect with each other because if they do so at the point of intersection there will be two directions of the magnetic field at that point which is impossible.
- The number of lines of force per unit area (area being perpendicular to lines) is proportional to the magnitude of strength of the magnetic field (magnetic field intensity) at that point. Thus, more concentration of lines of force represents stronger magnetic field.
- The lines of force tend to contract longitudinally or length-wise i.e. they possess longitudinal strain. Due to this property two unlike poles attract each other.
- The lines of force tend to exert lateral (sideways) pressure i.e. they repel each other laterally. This explain the repulsion between two similar poles.
- Lines of forces are imaginary, but the field obtained is real.

### 9.12 Magnetic flux( $\Phi$ ):

Magnetic flux is defined as the number of magnetic field lines passing through a certain area.

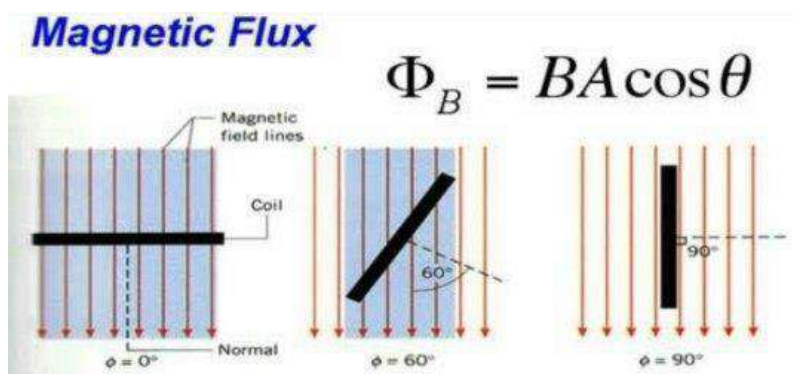

Fig. 9.18

It is denoted by  $\Phi$  and is given as

$$\Phi = \vec{B} \cdot \vec{A} = B A \cos \theta$$

Where, B = Magnetic Field

A = Surface Area

$\theta$  = Angle between the magnetic field and normal to the surface. Fig 9.18

**Unit: -**

Its unit in S.I is Weber and in C.G.S is maxwell

$$1 \text{ Weber} = 10^8 \text{ maxwell}$$

**Magnetic Flux Density(B): -**

Magnetic flux density is the amount of magnetic flux per unit area of a section that is perpendicular to the direction of flux.

Mathematically, it is represented as

$$B = \frac{\Phi}{A}$$

i.e. Magnetic flux density =  $\frac{\text{Magnetic flux}}{\text{Area}}$

**Unit: -**

Its unit in S.I is tesla i.e.

$$1 \text{ Tesla} = \frac{1 \text{ weber}}{(1 \text{ metre})^2}$$

Its unit in C.G.S is gauss i.e.

$$1 \text{ Gauss} = 1 \text{ maxwell}/(1\text{cm})^2$$

And  $1 \text{ Tesla} = 10^4 \text{ Gauss}$

## **EXERCISE**

### **VERY SHORT ANSWER QUESTIONS (2 Marks each)**

1. How do you define electric potential?
2. What is potential and potential difference.
3. Which of the following is not a vector (i) Electric intensity (ii) electric potential?
4. What is the relation between farad and statfarad?
5. What is magnetic flux?
6. What is capacitance?
7. Write the unit and formula of capacitance.
8. Write the unit and formula of electric field
9. Find the relationship between relative permittivity and absolute permittivity.

### **SHORT ANSWER QUESTIONS (5 Marks each)**

10. State and explain Coulomb's law of electrostatics?
11. How do you define a unit charge in CGS system and in SI? How are they related with each other?
12. How do you define capacity of a conductor?
13. How do you define electric potential at a point?
14. State and define units of electric potential in CGS system and in SI. How are they related with each other?
15. State and define units of capacity in CGS system and in SI.
16. Obtain a relation between (i) volt and statvolt (ii) Tesla and Gauss.
17. Write the properties of magnetic lines of force.
18. Discuss the principle of a capacitor.
19. Define magnet. State its properties.
20. State and explain Coulomb's law of magnetostatic.

### LONG ANSWER QUESTIONS (10 Marks each)

1. State and explain Coulomb's law of electrostatics. Discuss the nature and value of constant of proportionality involved in it.
2. (a) How do you define Electric intensity at any point in an Electric field? Obtain an expression for the same due to charge "q" at a distance "r" from it.  
(b) Obtain the unit and dimension for permittivity  $\epsilon_0$ .
- 3.(a) Obtain the expression for the capacity of a combination of three capacitors connected in series with each other.  
(b) Three capacitors each of  $3\mu\text{f}$  are connected in series with each other. Calculate the resultant capacity of the combination.
4. (a) What will be net capacity of the combination when n number of capacitors are connected in parallel with each other?  
(b) Three condensers each of  $3\mu\text{f}$  are connected in parallel with each other. Calculate the net capacity of the combination.

## UNIT-10

### (CURRENT ELECTRICITY)

Charge in motion constitute an electric current. Such currents occur naturally in many situations. Lightning is one such phenomenon, in which charges flow from the clouds to the earth through the atmosphere, sometimes with disastrous results. The flow of charges in lightning is not steady, but in our everyday life, we see many devices where charges flow in a steady manner, like water flowing smoothly in a river. A torch and a cell driven clock are the examples of such devices. In this chapter, we will discuss some of the basic laws concerning steady electric current and its application in different electrical circuits.

#### 10.1 Electric current:

The current through a given cross-sectional area in a conductor is defined as the time rate of flow of charge through that area.

$$\text{Mathematically, Average current}(I_{av}) = \frac{\Delta q}{\Delta t}$$

$$\text{Instantaneous current}(I) = \frac{dq}{dt}$$

Electric current is a scalar quantity

Dimensional formula  $[I] = [A] = [M^0L^0T^0A^1]$

SI Unit - Ampere

$$1 \text{ A} = \frac{1\text{C}}{1 \text{ s}}$$

The current is said to be one ampere if charge is being transferred at a rate of 1Coulomb per second.

#### 10.2 Ohm's Law:

It states that at constant temperature current flowing through a conductor is directly proportional to the potential difference between the two ends of the conductor.

$$\begin{aligned} \text{Mathematically, } I &\propto V \\ I &= \frac{1}{R} V \\ V &= I R \end{aligned}$$

Where, V = potential difference between the ends

I = current flowing in the conductor

R = Resistance of the conductor

Resistance is a material property which depends on the temperature and geometry of the conductor

$$R = \rho \frac{l}{A}$$

Where,  $\rho$  = Resistivity or specific resistance of conductor, it depends upon the nature of material of conductor.

$A$  = Area of cross section of conductor perpendicular to the direction of flow of current.

$l$  = length of the conductor along the direction of current.

$$\tan\theta = \text{slope} = \frac{I}{V} = \frac{1}{R}$$

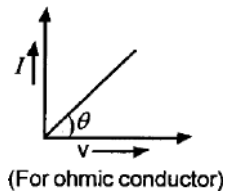

Fig. 10.1

The conductor which obeys ohm's law and the  $V \sim I$  graph ( a straight line passing through origin) is called Ohmic conductor.

Example - All metallic conductor.

Application of Ohm's Law:

- Ohm's law is used for calculating the current if the resistance and potential difference are known.
- The resistance of a material can be estimated by supplying a known amount of voltage and measuring the current flowing through it.
- Ohm's law is used to maintain the desired voltage drop across the electric components.

Limitation: Ohm's law is not applicable in diodes and transistor.

### 10.3 Combination of Resistors

#### (i) Series

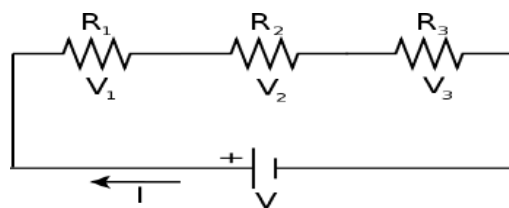

Fig. 10.2

In series connection, current through each resistor remains same but distribution of potential takes place i.e.  $V = V_1 + V_2 + V_3 \dots$

$$R_{eq} = R_1 + R_2 + R_3 + \dots$$

$R_{eq}$  = Equivalent Resistance of series combination

(ii) Parallel

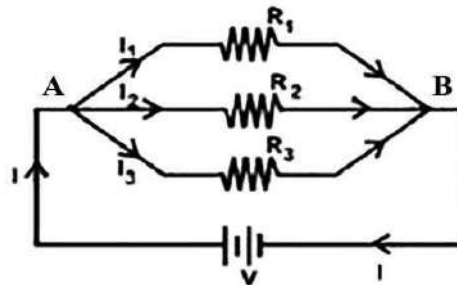

Fig. 10.3

In parallel connection, potential through each resistor remains same but distribution of current takes place i.e.  $I = I_1 + I_2 + I_3 \dots$

$$\frac{1}{R_{eq}} = \frac{1}{R_1} + \frac{1}{R_2} + \frac{1}{R_3} + \dots$$

$R_{eq}$  = Equivalent Resistance in Parallel Connection

#### 10.4 Kirchhoff's rule

First Law Kirchhoff's current rule (KCL)

It states that the algebraic sum of currents meeting at a point in a junction is zero.

Explanation:- To explain this law consider a number of wires connected at a point P. Currents  $i_1, i_2, i_3, i_4,$  and  $i_5$  flow through these wires in the directions as shown in figure 10.4.

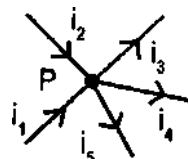

Fig.10.4

To determine their algebraic sum of electric currents, we assume the following sign conventions

- (i) The currents approaching a given point are taken positive
- (ii) The currents leaving the given point are taken as negative

Following the sign conventions, we find that  $i_1, i_2$  are positive while  $i_3, i_4$  and  $i_5$  are negative. So

$$i_1 + i_2 - i_3 - i_4 - i_5 = 0$$

$$\sum i_j = 0$$

Second law Kirchhoff's voltage Law (KVL)

It states that the algebraic sum of potential difference & emf (electromotive force) across a closed loop is zero.

$$\text{i.e. } \sum emf + p.d = 0 \quad \text{where p.d} = \text{potential difference}$$

Explanation:

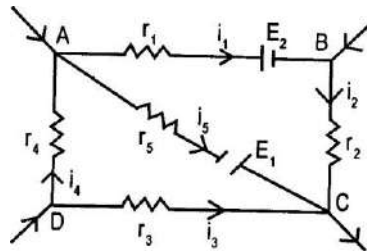

Fig. 10.5

Figure 10.5 shows a closed electric circuit ABCD containing resistance  $r_1, r_2, r_3, r_4$  and  $r_5$  in the parts AB, BC, CD, DA and AC respectively. Also let  $i_1, i_2, i_3, i_4, i_5$  be the respective currents flowing in these parts in the directions shown by arrow heads. Two sources of emf's  $E_1, E_2$  are also connected in the mesh.

In order to use Kirchoff's voltage rule, we will assume the following sign conventions.

- (i) While going along the loop if the current flows in that direction then it taken to be +ve otherwise -ve
- (ii) While going along the loop if we will face first +ve terminal of the emf then it is taken to be +ve otherwise -ve.

Applying KVL to mesh ABCA

$$i_1 r_1 + E_2 + i_2 r_2 + E_1 - i_5 r_5 = 0$$

$$\Rightarrow E_1 + E_2 = i_5 r_5 - i_1 r_1 - i_2 r_2$$

$$\Rightarrow \sum E = \sum ir$$

Applying KVL to mesh ACDA

$$i_5 r_5 - E_1 - i_3 r_3 + i_4 r_4 = 0$$

$$\Rightarrow E_1 = i_5 r_5 - i_3 r_3 + i_4 r_4$$

$$\Rightarrow \sum E = \sum ir$$

### 10.5 Wheatstone Bridge

Wheatstone bridge is an electrical arrangement which forms the basis of most of the instruments used to determine an unknown resistance.

Construction:- It consists of four resistance P, Q, R & S connected in the four arms of a square ABCD. A cell of emf E is connected between the points A & C through one way key  $K_1$ . A sensitive galvanometer of resistance G is connected between the terminals B & D through another one way key  $K_2$ . After closing the keys  $K_1$  &  $K_2$ , the resistance P, Q, R & S are so adjustable that the galvanometer shows no deflection. In this position the Wheatstone bridge is said to be balanced.

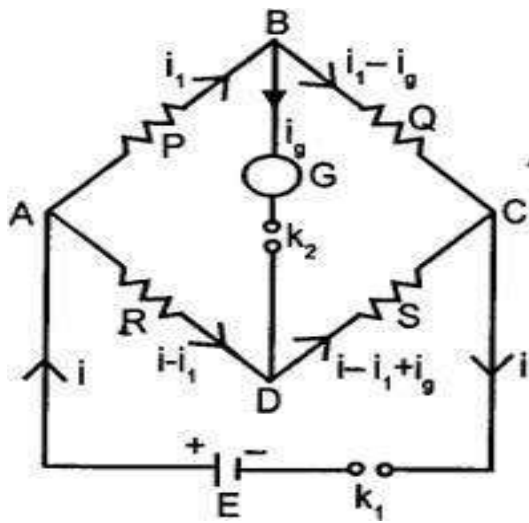

Fig.10.6

Explanation:- Using Kirchhoff's current law, the distribution of current and their directions through various resistance are as shown in fig 10.6.

Applying KVL to mesh ABD

$$i_1P + i_gG - (i - i_1)R = 0 \quad \dots(i)$$

$$\text{In mesh BCDB } (i_1 - i_g)Q - (i - i_1 + i_g)S - i_gG = 0 \quad \dots(ii)$$

Balanced condition:-

The values of P, Q and R are so adjusted that the galvanometer shows no deflection i.e., the current through galvanometer is zero. In this condition B and D are at same potential which is called as the balanced condition of the bridge.

By putting  $i_g = 0$ , equations (i) & (ii) becomes

$$i_1P = (i - i_1)R \quad \dots(iii)$$

$$i_1Q = (i - i_1)S \quad \dots(iv)$$

Dividing equation (iii) by (iv)

$$\frac{i_1P}{i_1Q} = \frac{(i - i_1)R}{(i - i_1)S}$$

$$\frac{P}{Q} = \frac{R}{S}$$

This is the required balanced condition of the bridge.

EXAMPLE:-1. A Wheatstone bridge is assembled with resistance in arms AB, BC & AD as 5 ohm, 15 ohm, 3 ohm respectively. What resistance should be inserted in arm CD to make it balanced.

SOLUTION:-Applying Wheatstone bridge condition

$$\frac{P}{Q} = \frac{R}{S}$$

$$\Rightarrow \frac{R_{AB}}{R_{BC}} = \frac{R_{AD}}{R_{CD}} \Rightarrow \frac{5}{15} = \frac{3}{R_{CD}} \Rightarrow R_{CD} = 9 \text{ ohm}$$

## EXERCISE

Very short type questions(2marks each)

- 1- State ohm's law
- 2- Define Electric current & write down its dimensional formula.
- 3- Two resistances of 5 ohm and 10 ohm are connected in parallel. Eight such sets are connected in series. Calculate the total resistance.

Ans:-  $R_1 = \frac{10 \times 5}{10 + 5} = \frac{50}{15} = \frac{10}{3}$  ohm  
 $R_{eq} = \frac{10}{3} \times 8 = \frac{80}{3}$  ohm = 26.6 ohm

- 4- Two resistances of 10 ohm and 20 ohm are connected in series and twelve such sets are connected in parallel. Calculate the total resistance.

Ans:-  $R_1 = 10 + 20 = 30$  ohm  
 $R_{eq} = \frac{R_1}{12} = \frac{30}{12} = \frac{5}{2}$  ohm  
 $= 2.5 \Omega$

- 5- Calculate the total resistance when three resistance of 200 ohm, 100 ohm and 50 ohm are connected together: (i) in series and (ii) in parallel.
- 6- Two resistors when connected in parallel have equivalent resistance of 5/3 ohm. When in series the equivalent resistance is 12 ohm. Find their resistances.

Ans:-  $\frac{R_1 R_2}{R_1 + R_2} = \frac{5}{3}$  ohm (in parallel) and  $R_1 + R_2 = 12 \Omega$  (in series)

$$\frac{R_1 + R_2}{R_1 R_2} = \frac{5}{3} \Rightarrow (R_1 + R_2) = \frac{5}{3} \times 12 = 20$$

$$(R_1 - R_2)^2 = (R_1 + R_2)^2 - 4R_1 R_2 = 12^2 - 4 \times 20 = 144 - 80 = 64$$

$$\Rightarrow R_1 - R_2 = 8 \text{ ohm} \dots\dots\dots(1)$$

$$R_1 + R_2 = 12 \text{ ohm} \dots\dots\dots(2)$$

Adding (1) & (2)  $2R_1 = 20$

$$\Rightarrow R_1 = 10 \Omega, \quad R_1 + R_2 = 12$$

$$R_2 = 12 - R_1 = 2 \text{ ohm}$$

Short answer type questions(5marks each)

- 1- State and explain Kirchoff's Laws used for analysis of electrical network.
- 2- A wire of uniform thickness with a resistance of 27 ohm is cut into three equal pieces and they are joined in parallel. Find the equivalent resistance of the parallel combination.

Ans:-  $3R = 27 \Rightarrow R = 27/3 = 9 \Omega$

The above three resistance in parallel

Then  $R_{eq} = R/3 = 9/3 = 3 \Omega$

- 3- If the five resistance each of 20 ohm are connected in parallel then again the above resistance connected in series, find the ratio of the equivalent resistance in parallel to that in series.

Ans :- In parallel

$$R_1 = 20/5 = 4\Omega$$

In Series

$$R_2 = 20 \times 5 = 100\Omega$$

$$\frac{R_1}{R_2} = \frac{4}{100} = \frac{1}{25}$$

- 4- If a 0.6 A of current flows through a resistor. Voltage across two points of resistors is 12 V. What is the resistance of the resistor ?

$$\text{Ans:- } R = \frac{V}{I} = \frac{12}{0.6} = \frac{12}{6/10} = \frac{12 \times 10}{6} = 20\Omega$$

Long Answer Questions (10 mark each)

1. (a) State and explain Kirchhoff's Laws for electricity and obtain the condition for balanced Wheatstone bridge.

(b) Three arms of a Wheatstone bridge have resistances of  $P = 10\Omega$ ,  $Q = 20\Omega$ ,  $R = 80\Omega$ . What resistance should be inserted in fourth arm to have the bridge to be balanced ?

$$\text{Ans:- } \frac{P}{Q} = \frac{R}{S} \Rightarrow \frac{10}{20} = \frac{80}{S}$$

$$\Rightarrow S = \frac{80 \times 20}{10} = 160\Omega$$

2. (a) Draw the diagram and write down the formula for equivalent resistance in series and parallel combination.

(b) Three resistances each of 9 ohm are connected in parallel to an emf source and draws current of 3 ampere, find the value of emf.

$$\text{Ans:- } R_{eq} = \frac{R}{3} = \frac{9}{3} = 3\Omega, I = 3 \text{ ampere (given)}$$

$$\varepsilon = IR_{eq} = 3 \times 3 = 9 \text{ volt}$$

## UNIT-11

### ELECTROMAGNETISM & ELECTROMAGNETIC INDUCTION

#### 11.1 ELECTROMAGNETISM:

Ampere and a few other scientists established the fact that electricity and magnetism are inter-related. They found that moving electric charges produce magnetic fields. For example, an electric current deflects a magnetic compass needle placed in its vicinity. This naturally raises the question like: Is the converse effect possible? Can a moving magnet produce electric current? Does the nature permit such a relation between electricity and magnetism? The answer is a resounding yes! The experiments of Michael Faraday in England demonstrated conclusively that electric currents were induced in closed coils when subjected to changing magnetic fields.

#### ELECTROMAGNETIC INDUCTION

A charged body is capable of producing electric charge in a neighboring conductor. The phenomenon of induction of electricity due to electricity is called electric induction. A magnet is capable of producing magnetism in a neighboring magnetic substance. This phenomenon of production of magnetism due to magnetism is called magnetic induction. A current flowing through a wire produces a magnetic field around itself. This phenomenon of production of magnetism due to electricity is called magnetic effect of currents. The phenomenon of production of electricity due to magnetism is called electro-magnetic induction.

#### 11.2 FORCE ON A CONDUCTOR CARRYING CURRENT AND PLACED IN A MAGNETIC FIELD

A conductor has free electrons in it. When a potential difference is maintained across the two ends of the conductor, the electrons drift from lower potential to higher potential with a small velocity. These electrons constitute a current through the conductor. When the electrons (charged particles) move in a magnetic field, they experience a force  $\vec{F}$ .

Consider a conductor XY placed in a uniform magnetic field  $\vec{B}$  acting inwards at right angle to the plane of paper. Let a current  $i$  flows through the conductor from X to Y.

Let „dq“ be a small amount of positive charge moving from X to Y with a velocity  $\vec{v}$  [Fig. 11. 1]. The force  $d\vec{F}$  experienced by this charge is given by

$$d\vec{F} = dq (\vec{v} \times \vec{B})$$

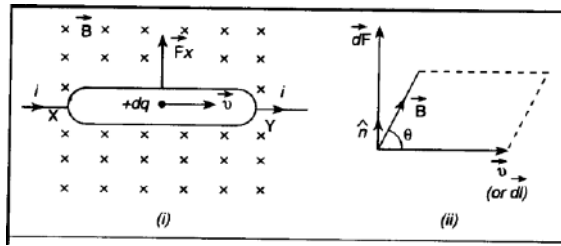

Fig.11.1

If the charge travels a small distance  $\vec{dl}$  in time  $dt$  then

$$\vec{v} = \frac{d\vec{l}}{dt}$$

$$\therefore d\vec{F} = dq \times \left( \frac{d\vec{l}}{dt} \times \vec{B} \right) = \frac{dq}{dt} (d\vec{l} \times \vec{B})$$

$$\text{or } \vec{dF} = i (\vec{dl} \times \vec{B}) \dots \dots \dots (1)$$

Direction of the length  $dl$  is taken to be the direction of advancing current i.e. from X to Y.

Applying the rule of cross-product, it can be seen that force  $dF$  acts vertically upwards as shown in fig 11.1(ii)

Net force  $\vec{F}$  acting on the conductor can be obtained by integrating equation (1)

$$\vec{F} = \int d\vec{F} = i \int d\vec{l} \times \vec{B}$$

$$\text{or } \vec{F} = i (l \times B)$$

$$\text{or } \vec{F} = ilB \sin \theta \hat{n}$$

where  $\hat{n}$  is a unit vector in a direction perpendicular to the plane containing  $\vec{l}$  and  $\vec{B}$ , „ $\theta$ “ is the angle between  $\vec{l}$  and  $\vec{B}$ .

(i) Magnitude of force. Magnitude of the force is given by

$$|\vec{F}| = Bil \sin \theta$$

It is clear that the magnitude of the force depends upon the angle between the direction of current and the lines of force of a magnetic field.

(ii) Direction of force. Direction of force  $\vec{F}$  can be obtained by applying any of the following rule.

(a) Rule of cross-product.

Force  $\vec{F}$  acts in a direction perpendicular to the plane containing  $\vec{l}$  and  $\vec{B}$ , while its sense is decided by right hand thumb rule. It may be noted that we are taking  $\vec{l}$  as a vector quantity whose length gives the length of current element and whose direction is same as that of flow of electric current through it.

(b) Fleming's left hand rule. Direction of force  $\vec{F}$  can also be obtained by applying Fleming's left hand rule which is stated as follows :

*Stretch first finger/forefinger, central finger/middle finger and the thumb of the left hand in mutually perpendicular directions. If the first finger points towards magnetic field, central finger points towards electric current then the thumb gives the direction of force acting on the conductor.*

It should be clearly kept in mind that Fleming's left hand rule can only be applied when the direction of motion of charged particles (currents) is perpendicular to the lines of force of magnetic field. In case the charged particles move at any other angle, direction of  $\vec{F}$  can be obtained by applying the rule of cross-product.

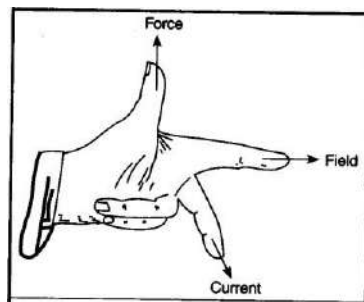

Fig.11.2

Case (i) If the conductor is placed at right angle to the field, then

$$\theta = 90^\circ$$

$$\therefore \sin \theta = 1$$

$$\text{So } |\vec{F}| = i l B \text{ (Maximum)}$$

Case (ii) If the length of the conductor is along the direction of lines of force, then

$$\theta = 0^\circ \text{ or } \theta = 180^\circ \quad \therefore \sin \theta = 0$$

$$\text{So } |\vec{F}| = 0$$

Thus, no force is experienced by current carrying conductor when its length is parallel to the lines of force of magnetic field whatever be the magnitude of electric current.

### 11.3 FARADAY'S LAWS OF ELECTROMAGNETIC INDUCTION

Faraday's laws deal with the induction of an electromotive force (e.m.f) in an electric circuit when magnetic flux linked with the circuit changes. They are stated as follows:

(i) Faraday's first law (qualitative)

Whenever magnetic flux linked with a circuit changes, an e.m.f is induced in it. The induced e.m.f exists in the circuit so long as the change in magnetic flux linked with it continues.

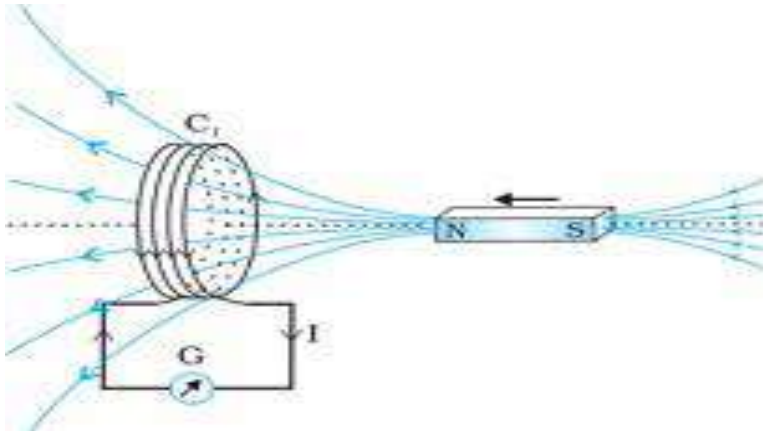

Fig.11.3

(ii) Faraday's second law (quantitative)

The induced e.m.f. is directly proportional to the negative rate of change of magnetic flux linked with the circuit.

If „ $d\phi_B$ ” is the change in magnetic flux linked with a circuit, that takes place in a time  $dt$ .

$$\text{Rate of change of magnetic flux} = \frac{d\phi_B}{dt}$$

If „ $E$ ” is e.m.f induced in the circuit as a result of this change,

$$E \propto -\frac{d\phi_B}{dt} \text{ or } E = -K \frac{d\phi_B}{dt}$$

By selecting the units of „ $E$ ”, „ $\phi_B$ ” and „ $t$ ” in a proper way, we can have

$$K = 1 \quad \therefore E = -\frac{d\phi_B}{dt}$$

$$\text{If } N = \text{no. of turns in the coil then, } E = -N \frac{d\phi_B}{dt}$$

Negative sign is due to direction of induced e.m.f, opposes the change in magnetic flux.

#### 11.4 LENZ'S LAW

It deals with the direction of e.m.f induced in the circuit due to a change in magnetic flux linked with it.

“ It states that direction of induced e.m.f is such that it tends to oppose the very cause which produces it”.

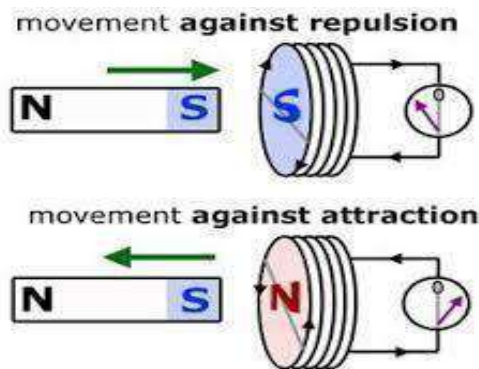

Fig.11.4

EXAMPLE :-1. A field of 0.0125 T is at right angles to a coil of area  $5 \times 10^{-3} \text{ m}^2$  with 1000 turns. It is removed from the field in  $1/20$  s. Find the e.m.f produced.

SOLUTION :- Given  $B = 0.0125 \text{ T}$ ,  $A = 5 \times 10^{-3} \text{ m}^2$ ,  $n = 1000$

If  $(\phi_B)_1$  and  $(\phi_B)_2$  be the magnetic flux linked with the coil inside and outside the magnetic field.

$$(\phi_B)_1 = nBA = 1000 \times 0.0125 \times 5 \times 10^{-3} = 625 \times 10^{-4} \text{ Wb}, (\phi_B)_2 = 0$$

$$d\phi_B = (\phi_B)_2 - (\phi_B)_1 = -625 \times 10^{-4} \text{ Wb}$$

$$\text{Induced e.m.f. „E“ is } E = - \frac{d\phi_B}{dt} = - \frac{-625 \times 10^{-4}}{1/20} = 12500 \times 10^{-4} \text{ V} \quad \left[ \frac{1}{dt} = \frac{1}{20 \text{ s}} \right]$$

$$\text{Or } E = 1.25 \text{ V}$$

### 11.5 FLEMING'S RIGHT HAND RULE

It is a rule to find the direction of induced current in a conductor with given direction of magnetic field and force on the conductor. It can be stated as follows:

Stretch the first finger, central finger and the thumb of the right hand in three mutually perpendicular directions. If first finger points towards the magnetic field, thumb points towards the direction of motion of the conductor, then, the direction of central finger gives the direction of the induced current set up in the conductor.

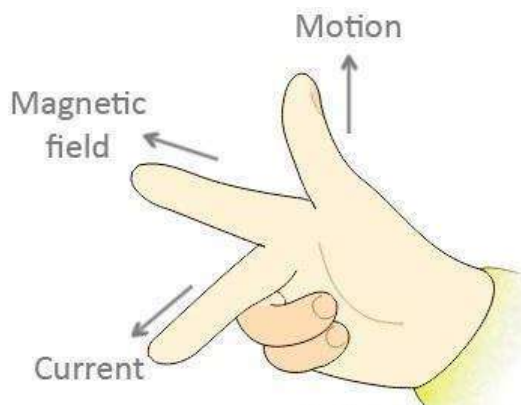

Fig.11.5

Consider a coil ABCD, turning in between the two pole pieces of a magnet as shown in fig. 11.6. Let the direction of rotation of the coil be such that AB moves out of the plane of the paper while CD moves into. Applying Fleming's right hand rule separately on AB and CD, it can be seen that direction of induced current is from „B to A“ and „D to C“

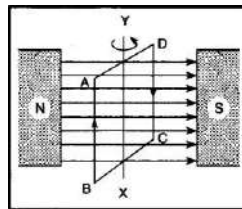

Fig.11.6

### 11.6 Comparison between Fleming's Right hand rule and Fleming's left hand rule

#### Fleming's Left hand Rule:

- (i) This rule is used to determine the direction of force on a moving charge or on a current carrying conductor placed in a magnetic field.
- (ii) Central finger signifies electric current on the conductor.
- (iii) Thumb signifies the direction of magnetic force
- (iv) The purpose of the rule is to find the direction of motion of the current carrying conductor, when placed in a magnetic field.
- (v) It is applied in electric motors in which electric current flowing through the conductor and magnetic field are the causes.

#### Fleming's Right hand Rule :

- (i) This rule is used to determine the direction of induced electric current
- (ii) Central finger signifies induced current within the conductor
- (iii) Thumb signifies the direction of motion of conductor
- (iv) The purpose of the rule is to find the direction of induced current when conductor moves in a magnetic field.
- (v) It is applied in electric generators where the motion of conductor in a magnetic field is the cause.

## EXERCISE

### Very short type questions(2marks each)

1- Define electromagnetic induction.

Ans:- Whenever there will be change in magnetic flux linked with the coil an emf is induced in the coil i.e. phenomenon of production of electricity due to the magnetism is called electromagnetic induction.

2- A straight conductor having length „l“ carrying current „I“ is placed along the direction of magnetic field „B“, Calculate the force on the conductor.

Ans:-  $F = i l B \sin\theta$

$$\text{Since } \theta = 0^\circ, F = i l B \sin 0 = 0$$

3- State Faraday's Qualitative law of electromagnetic induction.

4- State Lenz's law.

5- State Faraday's Quantitative law of electromagnetic induction.

### Short answer type questions(5marks each)

1- State & explain Fleming's Right hand Rule

2- State & explain Fleming's Left hand Rule

3- Write down the comparison between Fleming's Left hand & Right hand Rule

4- State & explain Faraday's laws of electromagnetic Induction.

5- A magnetic field of 0.012T acts at right angles to the coil of area 0.01m<sup>2</sup> with 1500 turns. The coil is removed from the field in 0.1 sec. Calculate the emf induced in the coil.

$$\begin{aligned} \text{Ans:- Induced emf} &= -\frac{d\phi}{dt} \\ &= -N \frac{d(BA)}{dt} = -NA \frac{dB}{dt} \\ &= -1500 \times 0.01 \times \frac{0.012}{0.1} \\ &= -1.8 \text{ volt} \end{aligned}$$

### Long Answer Questions (10 mark each)

1. (i) Calculate the force on a conductor carrying current placed in a uniform magnetic field and discuss its different cases where the force will be maximum & minimum.

(ii) A straight conducting rod of length 2 meter carrying current 5 ampere is placed perpendicular to an external magnetic field  $B = 0.01$  Tesla. Calculate the force on the conductor.

$$\begin{aligned} \text{Ans:-} \quad F &= i l B \sin 90^\circ \\ &= 5 \times 2 \times 0.01 = 0.1 \text{ Newton} \end{aligned}$$

---

## UNIT-12 (MODERN PHYSICS)

“LASER” the word is uttered even by children now a days. The word is already accepted as a real word having verb form “to lase”. From its invention in 1960, laser has provided magic solutions to numerous problems. The growing predominance of lasers is undeniable in contemporary modern society. Summarily, lasers have revolutionized modern technology, and these are finding applications in all walks of human life such as manufacturing industries, defense system, scientific and medical applications, communication and information processing, entertainment, sensor optical switching, thousands of other areas have been found.

Wireless transmission is a form of unguided media and involves no physical link established between two or more devices, communicating wirelessly.

In this chapter we will discuss principle, properties, application of Laser and different types of wave propagation.

### 12.1 LASER AND LASER BEAM

The name **LASER** is an acronym for **Light Amplification by Stimulated Emission of Radiation**.

As the name suggests, **LASER is an optical device which produces light through a process of optical amplification based on the principle of stimulated emission of electromagnetic radiation.**

A **LASER** beam is highly monochromatic, extremely intense, coherent and highly parallel beam of light. A device which produces this kind of beam is quite often called a „LASER“.

### 12.2 Principle of laser :

#### a) **Stimulated absorption:**

We know that electrons exist at specific “energy levels” or “states” which is the characteristic of a particular atom or molecule. These energy levels can be imagined as orbits around the nucleus of an atom.

Usually, the atom exists in the lower energy state  $E_1$  (i.e ground state) and  $E_2$  be the higher allowed energy state. If a photon of light having energy  $\Delta E = E_2 - E_1$  is incident on this atom, the atom will absorb photon and jump to higher energy state  $E_2$ .

This process is called as stimulated absorption. The incident photon has stimulated the atom to absorb energy.

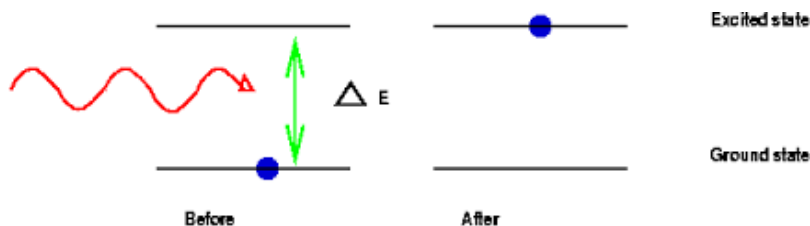

Stimulated Absorption (Fig. 12.1)

**b) Spontaneous emission:**

Suppose the atom is in the higher excited state  $E_2$ , if we just leave the atom there it will eventually come down to the lower energy state by emitting a photon having energy  $(E_2 - E_1)$ . This process is called spontaneous emission.

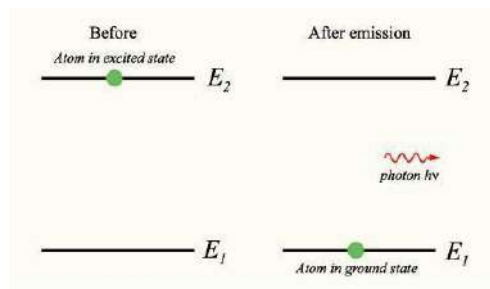

Spontaneous emission (Fig. 12.2)

**c) Stimulated emission:**

Atom stays about 10 nanoseconds in an excited state which is called as average life time of the atom to stay in that excited state. Hence, the atoms in an excited state is more likely to emit spontaneously. There are atoms which have certain excited state having life time of the order of millisecond such states are called as metastable states. If the atom is in such a metastable state with energy  $E_2$  and photon of energy,  $E_2 - E_1$  is incident on it, the incident photon interacts with the atoms in the higher energy state (metastable state) and brings the atoms to come down to the lower energy state.

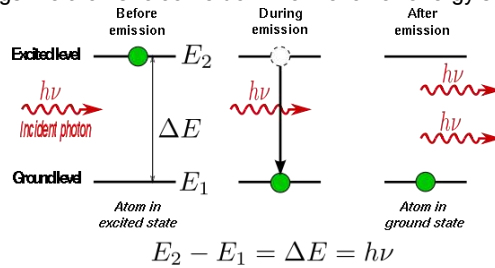

$$E_2 - E_1 = \Delta E = h\nu$$

Stimulated emission (Fig. 12.3)

A fresh photon is emitted in this process. In this case, the incident photon has stimulated the atom in the excited state to come down to the lower energy state.

The process in which the atom emits a photon due to its interaction with a photon incident on it is called as stimulated emission.

**d) Population inversion:**

$E_2$  = Energy of the metastable state

$E_1$  = Energy of the lower energy state

Suppose a photon of energy  $(E_2 - E_1)$  is incident on one of the atom in the metastable state, this atom comes down to the lower energy state „ $E_1$ ” by emitting a photon in the same phase (i.e., Coherent), Energy (i.e., same frequency or wave length) and direction as in the case of incident photon.

These two photons interact with two more atoms in the metastable state  $E_2$  and so on, as a result the number of photons keeps on increasing. All the photons have same phase, same energy and same direction, thus amplification of light will be achieved.

However, higher energy metastable state „ $E_2$ ” must have larger numbers of atoms than the number in the lower energy state „ $E_1$ ” for all the time to achieve the amplification and to obtain a stable lasing action.

When the higher energy state has more number atoms than the lower energy state, this condition is called as population inversion.

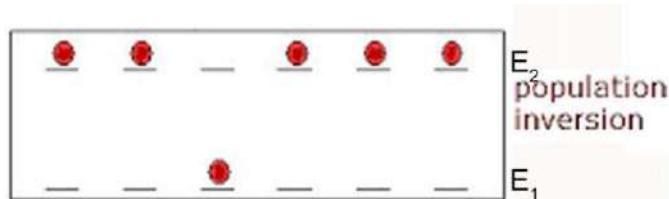

(Fig. 12.4)

**e) Optical pumping:**

To sustain the laser action, the number atoms in the higher energy state „ $E_2$ ” must be more than the atoms in the lower energy state „ $E_1$ ”.

The metastable state  $E_2$  should continue to get atoms and the atoms should be continuously removed from the lower state „ $E_1$ ” with the help of photons emitted by an external optical source. This process is called as optical pumping.

If the luminous energy (light) is supplied to a system for causing population inversion, then the pumping is known as optical pumping.

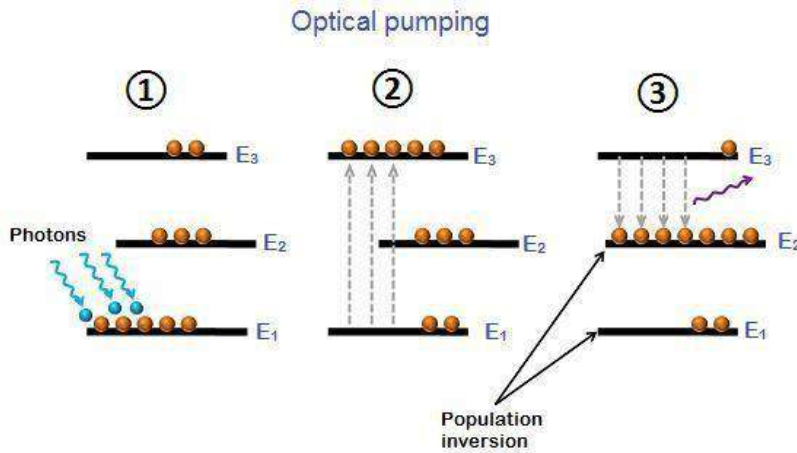

(Fig. 12.5)

**12.3 Properties of Laser Beam:**

(i) **Directionality:** Light emitted from conventional sources spread in all directions. Laser beam is highly parallel and directional. A narrow beam of light can be obtained from it.

(ii) **Intensity:** As the laser beam has the ability of focusing over an area as small as  $10^{-6}$  cm<sup>2</sup>, therefore, it is highly intense beam. Also, the constructive interference between the coherent photons lead to a high amplitude and hence a high intensity.

(iii) **Mono-chromaticity:** Light emitted from a laser is vastly more monochromatic than that emitted from a conventional mono-chromatic sources of light.

(iv) **Coherence:** The laser light is highly coherent in space and time. This property enables us to realize a tremendous spatial concentration of light power.

#### **PRINCIPLE BASED APPLICATIONS OF LASERS**

(i) **Laser in surgery:** Laser beam can be carried from source using optical fibers from one place to another and can be focused over an extremely small area. The beam travels through optical fibers suffering total internal reflections. As the beam is very powerful, it can cut the flesh and seal the blood oozing cells instantly allowing the surgery to be carried out without wasting blood. In laser surgery the cut is so fine that the patient does not feel the pain. Laser is used in eye surgery to attach a detached retina.

(ii) **Laser in industry:** As laser beam is very high power beam, it is employed in melting, cutting, drilling and welding metals. A powerful laser beam can cut a few cm thick iron sheet like a hot knife cutting butter.

(iii) **Laser in other branches of science:** One of the most important branch in chemistry is the study of the nature of chemicals bonds. A suitable laser can be employed to break the bond in a molecule by resonating it with the bond, helps to determine the structure of the molecule.

In astronomy radio-astronomers are frequently using it to determine the distances of planets and sub-planets.

(iv) **Laser in warfare:** Laser beams are capable of destroying enemy war planes. America is employing laser beam in their star war programme in which they will operate from artificial satellites to destroy enemy's inter-continental missiles etc. A laser gun can kill human-beings without any shot sound.

### **12.4: WIRELESS TRANSMISSION**

In electronic communication, radio waves propagate between a transmitter and a receiver. The signal must reach the receiver without any distortion or noise. Depending on the frequency of the signal and the distance over which it is to be transmitted, different methods are used. A wide range of research is going on to shape and improve the quality and speed of transmission. Also, the electronic components are being improved. Here, we will discuss the basic methods in a brief manner.

#### **a. Ground Waves:**

- A ground wave is a radio wave that travels along earth's surface. This is also known as surface wave.
  - The nature of surface influences the propagation. The ground wave travels better over a conducting surface for example, saline water.
  - For an optimum propagation with surface wave, vertical polarization is used. That is why self-radiating, vertical transmitters are used as antennas in long and medium wave radio stations in amplitude modulated broadcast.
-

- The maximum range of coverage depends on the transmitted power and frequency (few megahertz).
- The attenuation of ground waves increases rapidly with increase in frequency.
- Ground waves have the tendency to bend around the corners of the surface of earth or obstructions during propagation which makes them more efficient and also these are not affected by the change in atmospheric conditions.
- In submarine, propagation of very low frequency (30 Hz to 300 Hz) is needed. Hence, ground wave is the only efficient method.
- As discussed above, the disadvantage of ground wave is high-frequency waves cannot be transmitted as the energy losses are more because of the absorption of energy in the earth's atmosphere.
- The transmission of ground wave is effective for few MHz and is not suitable above 30 MHz

**b. Sky Waves:**

- For the frequency range of few MHz to 30 MHz, radio wave is reflected back to earth from the ionosphere of atmosphere and is utilized for long range communication. This mode of propagation is known as sky wave propagation.
- The ionosphere extends from a height of about 70 km to 400 km above the earth's surface. It contains a large number of charged particles which result from the absorption of sun's radiation by the air molecule.
- The high frequency above 30 MHz can penetrate ionosphere due to high energy.
- However, as in the case of total internal reflection, the ionospheric layer can reflect the wave with frequency about 3 MHz to 30 MHz towards the Earth's surface.
- The sky wave from the transmitter is directed towards the ionosphere. It bounces between the ionosphere and earth to reach the receiver.

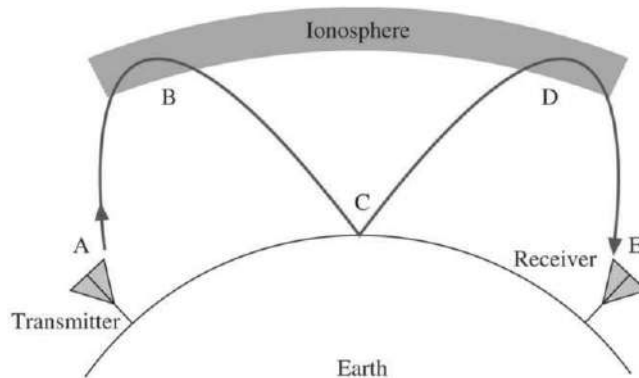

Fig. 12.2

- The sky wave method is essential for the long-range propagation of high frequency radio wave.
- Satellite communication and mobile communication depends on the upper atmospheric condition and hence take place using sky wave propagation.

- For sky wave propagation, gaseous medium is required. Hence, communication with sky wave is not possible in space where atmosphere is not present.

**c. Space Wave:**

- High frequency electromagnetic waves (>40 MHz) cannot be propagated as ground wave as they get attenuated and also cannot be propagated as sky wave as they penetrate the ionosphere and escape.
- Such high frequency waves are propagated as space wave. In space wave propagation, the wave emitted from the transmitter travels in a straight line towards the receiver antenna.
- Space wave method is used for satellite communication, line of sight (LOS) communication, microwave linking and radar communication.
- TV signals having frequency above 50 MHz can propagate only via space wave.

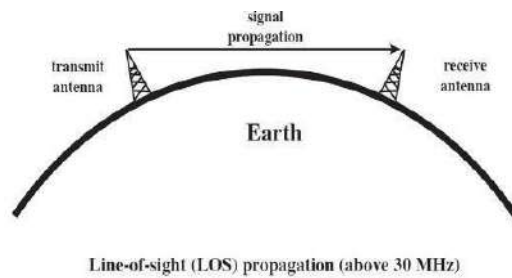

Fig. 12.3

- Different types of electromagnetic wave propagation discussed above are summarized in the figure given below.

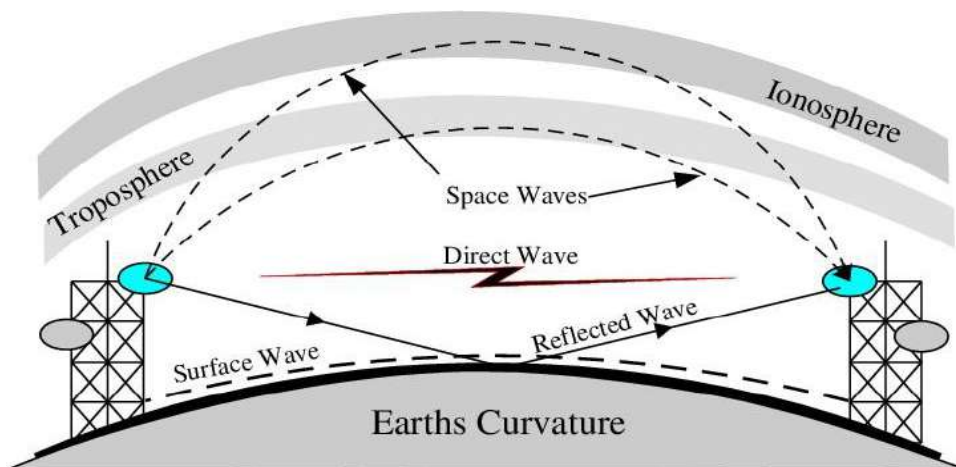

Fig. 12.4

# EXERCISE

VERY SHORT ANSWER QUESTIONS (2 Marks each)

1. State the full form of LASER.
2. State two characteristics of LASER.
3. Give one application of LASER.
4. Define spontaneous Emission.
5. Define stimulated emission.

SHORT ANSWER QUESTIONS (5 Marks each)

1. How can LASER help us in industries?
2. What is the use of LASER in surgery?
3. What is meant by directionality of LASER?
4. Explain the different applications of LASER.
5. What is optical Pumping?
6. Write down the short notes on population inversion.

LONG ANSWER QUESTIONS (10 Marks each)

1. Describe the principles of LASER.
  2. Describe the properties and uses of LASER.
  3. Write short notes on:
    - (i) Ground wave
    - (ii) Sky wave
    - (iii) Space wave
-